

CONEC®

TECHNOLOGY IN CONNECTORS™

EINBAUFLANSCH SMT • SOCKETS SMT





Technology in Connectors™

Als führender Hersteller von Steckverbindern entwickelt, produziert und vermarktet CONEC Produkte weltweit an die Elektronik- und Kommunikationsindustrie. CONEC hat sich verpflichtet, zum Fortschritt in der Steckverbinderindustrie beizutragen und die Kunden durch Neuheiten, Qualität und exzellenten Service zufrieden zu stellen.

Weltweit und kundenorientiert agiert die Organisation als Team. Mit eigenen Niederlassungen und Vertretungen ist CONEC in zahlreichen Ländern dieser Welt präsent.

Unsere Verkaufsberater vor Ort übermitteln alle Informationen direkt an die verantwortlichen Abteilungen nach dem Prinzip der kurzen Wege. Daraus resultieren Betreuung in der jeweiligen Landessprache, kurzfristige Reaktion und kompetente Beratung, wenn es darauf ankommt.



CONEC Germany, Lippstadt



CONEC USA, Garner



CONEC Canada, Brampton



As a leading Connector manufacturer CONEC develops, produces and markets Connectors worldwide to the electronic and communications industry. CONEC is committed to contribute to progress in interconnect technology, and to satisfy and delight customers through innovation, quality manufacturing and superior services.

CONEC provides global account management in a customer's home country and combines the information received for product and design and delivery of the end product to the customer's multiple manufacturing locations worldwide.

Local sales and engineering support around the globe provides the customer knowledgeable assistance in their own language to fully communicate and to understand the needs of their business environment.



SAL M12x1 Einbauf lansche SMT/Sockets SMT

Nomenklatur/Nomenclature

S A L - 1 2 - F K - 4 - X 9 / 1 4 / SMT

SAL
Sensor Actor Line

Baugröße/Installation size
12 = M12x1

Codierung/Coding
= A-codiert/coding = B-codiert/coding
S = A-codiert geschirmt/coding shielded = D-codiert/coding

Ausführung/Configuration
F = Flansch/Socket
I = Isolierkörper/Insulation Body

Bauform/Configuration
K = Kupplung/Female Connector
S = Stecker/Male Connector

Montage/Assembly
= Frontmontage/Frontmounting

Ausführung/Building
= Axial

Polzahl/Number of poles
4 = 4-pol/4-pos 8 = 8-pol/8-pos
5 = 5-pol/5-pos

Anschlussart/Type of connection
X9 = Einbauhöhe/Installation Height [mm]
X13 = Einbauhöhe/Installation Height [mm]

Verschraubung/Screw connection
14 = M14x1

Anschluss/Termination
SMT = Reflow Löt-Prozess/Reflow soldering

SAL M12x1 Einbauf lansche SMT/Sockets SMT

Produktspezifikation/Product specification

Werkstoffe/Basic material	
Kontakt/Contact	CuZn/CuSn
Kontakt oberfl äche/Contact plating	Ni, Au gal.
Kontakttr äger/Contact carrier	LCP GF
Lötblech/Soldering sheet	CuZn, Ni Sn
Flanschgeh äuse/Socket housing	CuZn, Ni
Dichtung/Sealing	FPM
Schirmblech/Shroud	CuSn/Ni sel. Sn

Technische Daten/Technical Data

Die Angaben auf den nachfolgenden Seiten basieren auf den unten aufgef ührten IEC-Normen.
Information on the following pages are basing on below mentioned IWE C-standards.

Bemessungsspannung/Rated voltage	IEC 61076-2-101
Strombelastbarkeit/Current rating	IEC 61076-2-101
Isolationswiderstand/Insulation resistance	IEC 60512
Verschmutzungsgrad/Pollution degree	IEC 60664-1
Steckzyklen/Mating cycles	IEC 60512-9a

Empfohlenes Drehmoment Einbauf lanschgeh äuse: 0,8-1 Nm/Recommended torque for housing: 0,8-1 Nm
Technische Änderungen vorbehalten. Technical subject to change without notice.

Isolierkörper Kupplung Insulation Body Female



Bezeichnung/ Description	pol./ pos	Codierung/ Coding	Art. Nr. Rolle/ Part-No. Tape & Reel	Art. Nr. Schüttgut/ Part-No. Bulk material
SAL-12-1K4-X9/SMT	4	A	43-01848TR	43-01848
SAL-12-1K5-X9/SMT	5	A	43-01849TR	43-01849
SAL-12-1K8-X9/SMT	8	A	43-01965TR	43-01965



Isolierkörper Kupplung mit Schirmfeder Insulation Body Female with shielding



Bezeichnung/ Description	pol./ pos	Codierung/ Coding	Art. Nr. Rolle/ Part-No. Tape & Reel	Art. Nr. Schüttgut/ Part-No. Bulk material
SAL-12S-1K4-X9/SMT	4	A	43-01850TR	43-01850
SAL-12S-1K5-X9/SMT	5	A	43-01851TR	43-01851
SAL-12S-1K8-X9/SMT	8	A	43-02115TR	43-02115
SAL-12B-1K4-X9/SMT	4	B	43-02032TR	43-02032
SAL-12B-1K5-X9/SMT	5	B	43-02033TR	43-02033
SAL-12D-1K4-X9/SMT	4	D	43-02034TR	43-02034

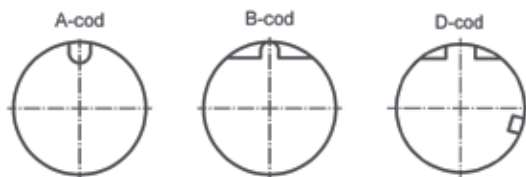

Isolierkörper Stecker Insulation Body Male

Bezeichnung/ Description	pol./ pos	Codierung/ Coding	Art. Nr. Rolle/ Part-No. Tape & Reel	Art. Nr. Schüttgut/ Part-No. Bulk material
SAL-12-IS4-X9/SMT	4	A	43-02026TR	43-02026
SAL-12-IS5-X9/SMT	5	A	43-02027TR	43-02027
SAL-12-IS8-X9/SMT	8	A	43-02028TR	43-02028

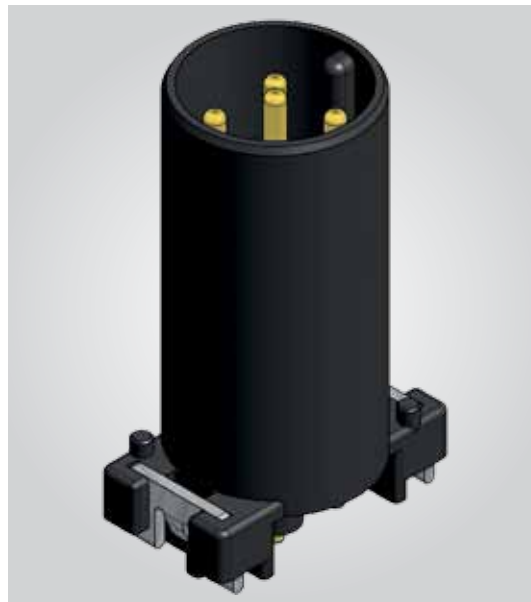
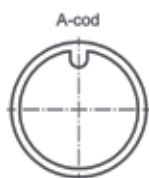

Isolierkörper Stecker mit Schirmfeder Insulation Body Male with shielding

Bezeichnung/ Description	pol./ pos	Codierung/ Coding	Art. Nr. Rolle/ Part-No. Tape & Reel	Art. Nr. Schüttgut/ Part-No. Bulk material
SAL-12S-IS4-X9/SMT	4	A	43-02118TR	43-02118
SAL-12S-IS5-X9/SMT	5	A	43-02119TR	43-02119
SAL-12S-IS8-X9/SMT	8	A	43-02120TR	43-02120
SAL-12B-IS4-X9/SMT	4	B	43-02030TR	43-02030
SAL-12B-IS5-X9/SMT	5	B	43-02031TR	43-02031

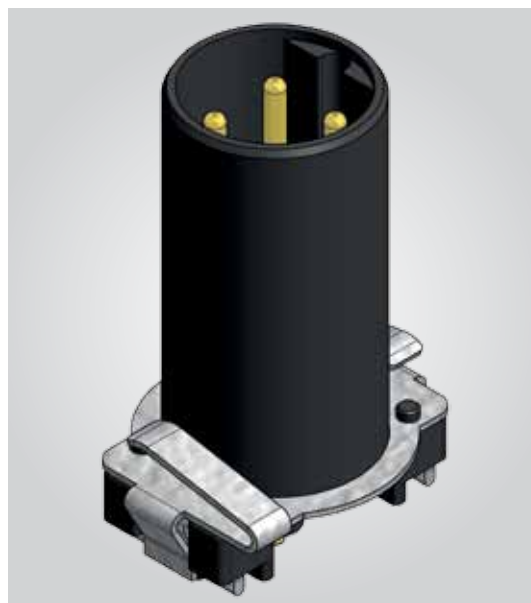
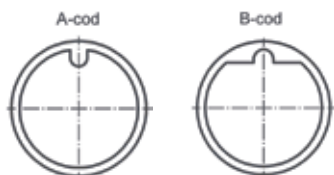

Isolierkörper Kupplung/Insulation Body Female

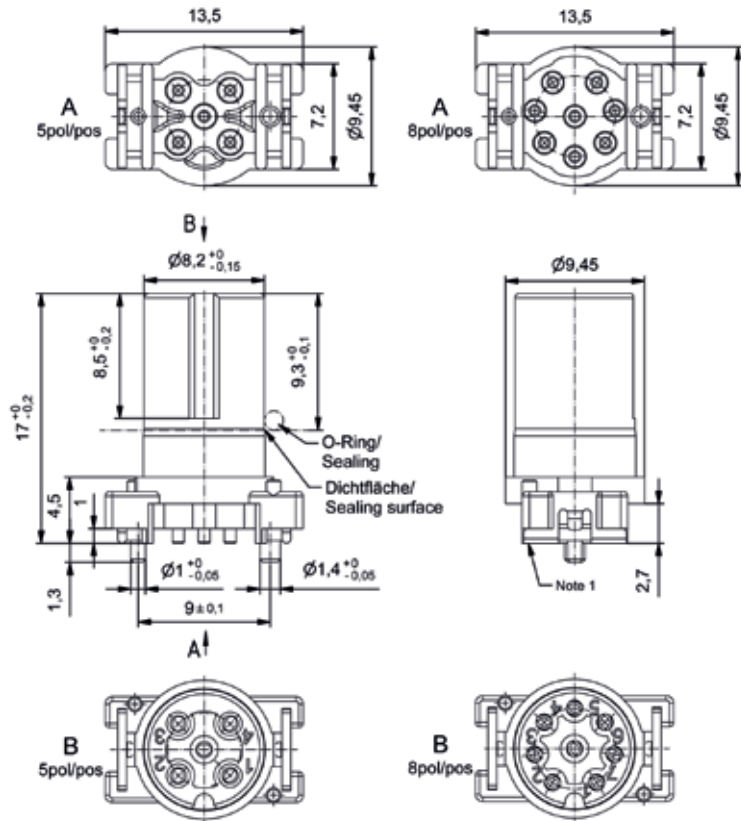

Layout Vorschlag 4-, 5-pol
Layout proposal 4-, 5-pos

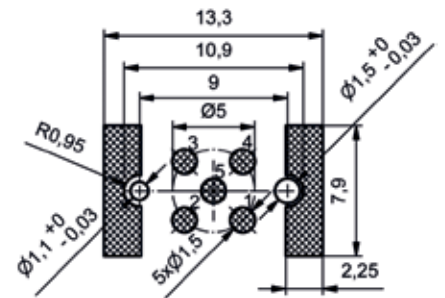

Isolierkörper Kupplung mit Schirmfeder Insulation Body Female with shielding

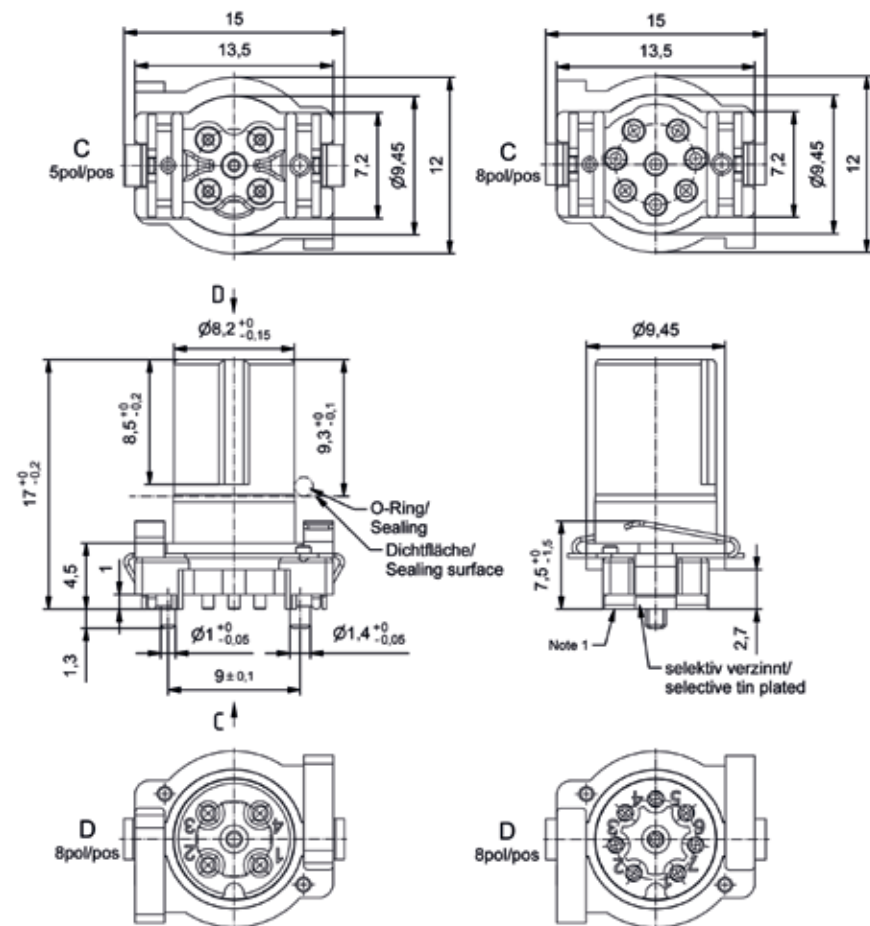

Layout Vorschlag 8-pol
Layout proposal 8-pos

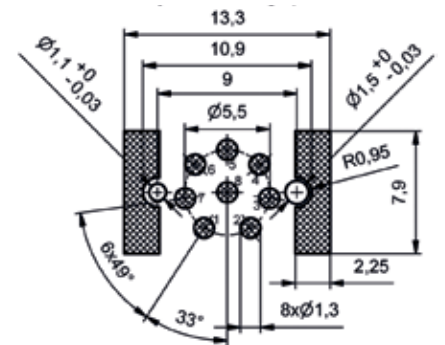

Note:
Koplanarität aller Kontakte, Lötbleche
und Schirmblech max 0,1 mm/
Coplanarity of all contacts, soldering sheets
and shroud max 0,1 mm

Isolierkörper Stecker/Insulation Body Male

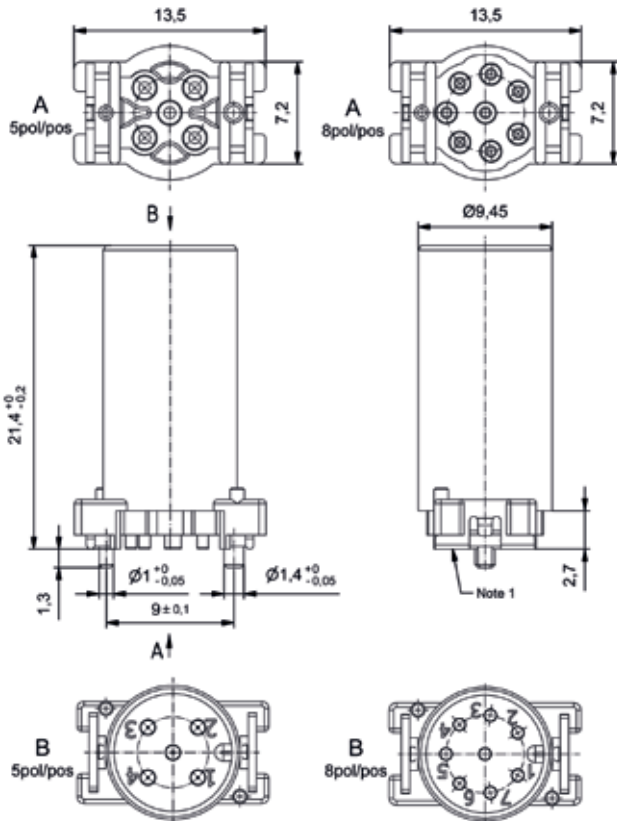

Layout Vorschlag 4-, 5-pol
Layout proposal 4-, 5-pos

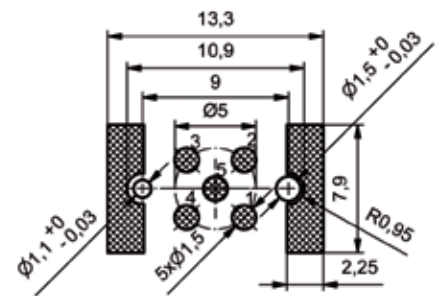

Isolierkörper Stecker mit Schirmfeder Insulation Body Male with shielding

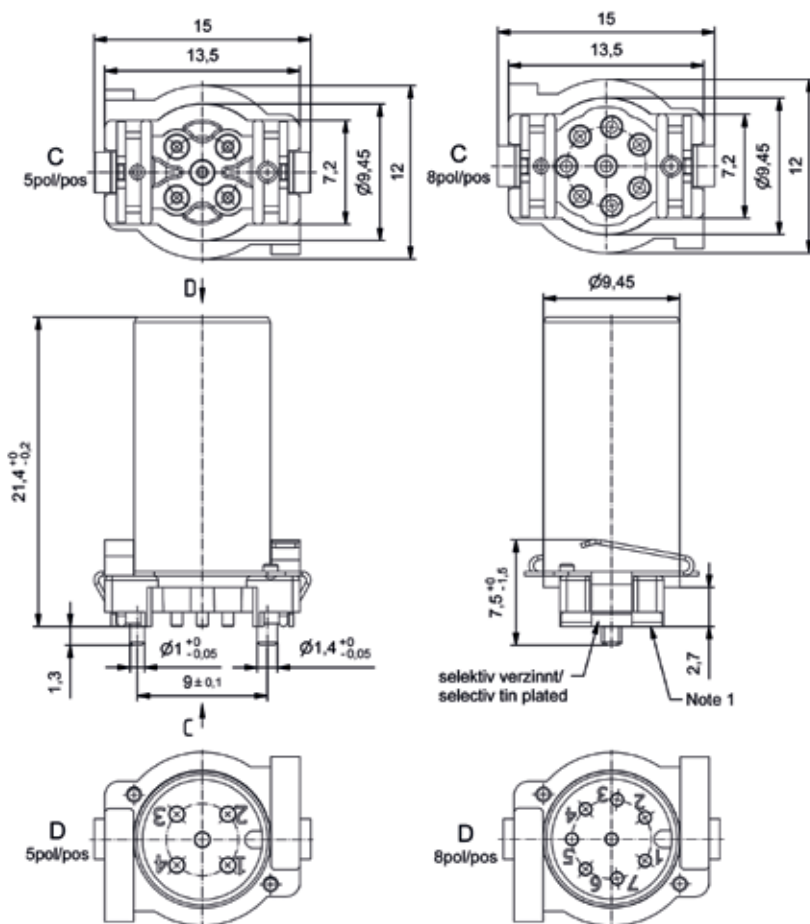

Layout Vorschlag 8-pol
Layout proposal 8-pos

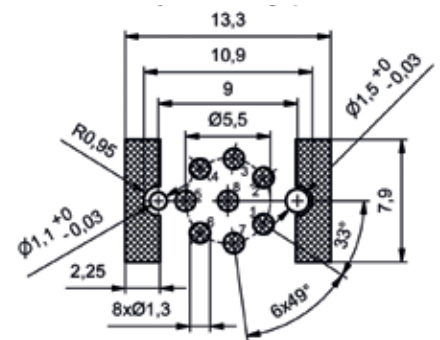

Note:
Koplanarität aller Kontakte, Lötbleche
und Schirmblech max 0,1 mm/
Coplanarity of all contacts, soldering sheets
and shroud max 0,1 mm

Einbaukomponenten
Mounting Hardware

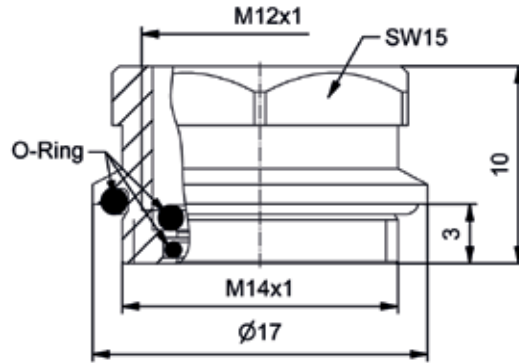

Flanschgehäuse Kupplung
Housing Female
Frontmontage/Frontmounting
Einbauhöhe/
Installation Height: 9,0 mm
Art. Nr./Part.-No.
43-01229

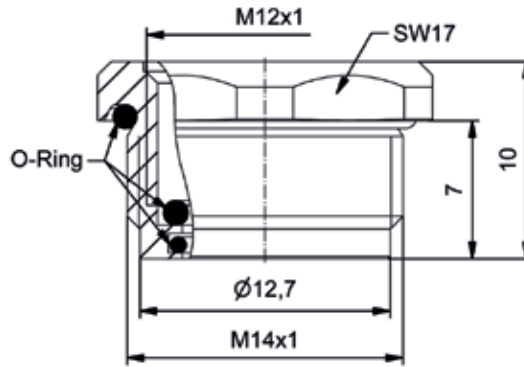

Flanschgehäuse Kupplung
Housing Female
Frontmontage/Frontmounting
Einbauhöhe/
Installation Height: 13,0 mm
Art. Nr./Part.-No.

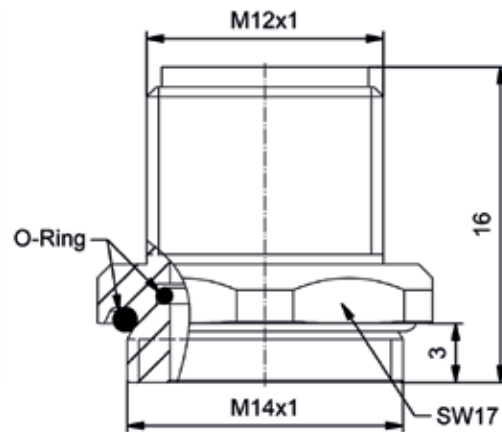

Flanschgehäuse Stecker
Housing Male
Frontmontage/Frontmounting
Einbauhöhe/
Installation Height: 9,0 mm
Art. Nr./Part.-No.

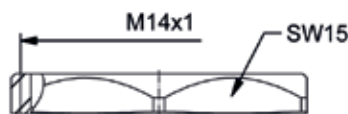

Sechskantmutter
Hexagon nut
Art. Nr./Part.-No.
43-02132

Flanschkupplung|Frontmontage|Einbauhöhe 9,0 mm
 Female Socket | Frontmounting | Installation Height 9,0 mm

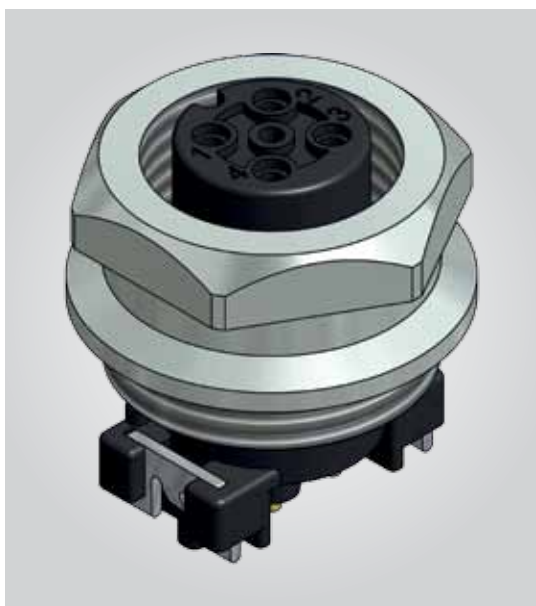

Bezeichnung/ Description	pol./ pos	Codierung/ Coding	Art. Nr. Rolle/ Part-No. Tape & Reel	Art. Nr. Schüttgut/ Part-No. Bulk material
SAL-12-FK4-X9/14/SMT	4	A	43-01852TR	43-01852
SAL-12-FK5-X9/14/SMT	5	A	43-01853TR	43-01853
SAL-12-FK8-X9/14/SMT	8	A	43-02116TR	43-02116

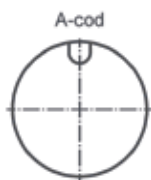

Flanschkupplung mit Schirmfeder|Frontmontage|Einbauhöhe 9,0 mm
 Female Socket with shielding | Frontmounting | Installation Height 9,0 mm

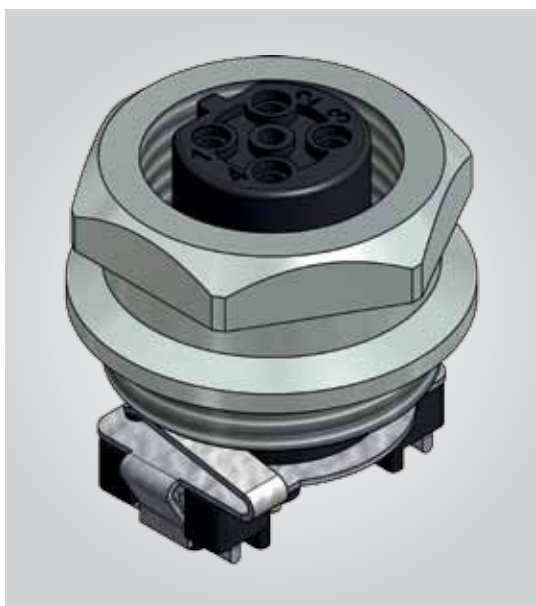

Bezeichnung/ Description	pol./ pos	Codierung/ Coding	Art. Nr. Rolle/ Part-No. Tape & Reel	Art. Nr. Schüttgut/ Part-No. Bulk material
SAL-12S-FK4-X9/14/SMT	4	A	43-01854TR	43-01854
SAL-12S-FK5-X9/14/SMT	5	A	43-01855TR	43-01855
SAL-12S-FK8-X9/14/SMT	8	A	43-02117TR	43-02117
SAL-12B-FK4-X9/14/SMT	4	B	43-02121TR	43-02121
SAL-12B-FK5-X9/14/SMT	5	B	43-02122TR	43-02122
SAL-12D-FK4-X9/14/SMT	4	D	43-02127TR	43-02127

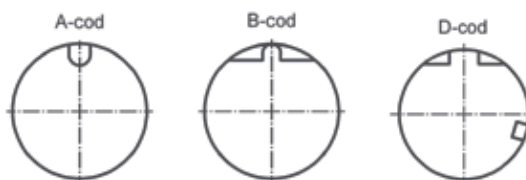

Flanschkupplung|Frontmontage|Einbauhöhe 13,0 mm
 Female Socket | Frontmounting | Installation Height 13,0 mm

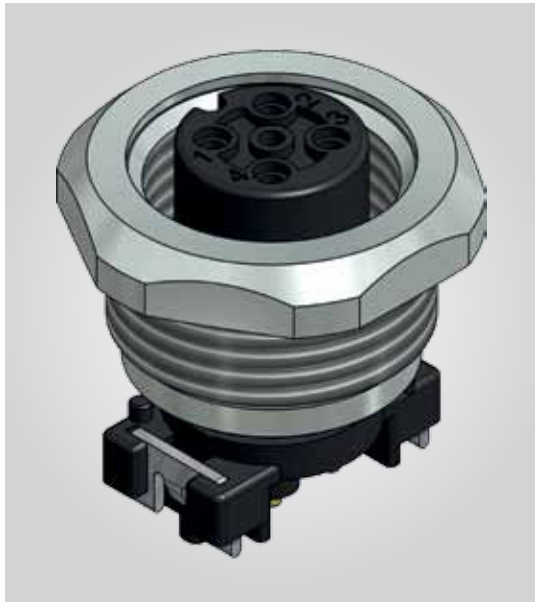

Bezeichnung/ Description	pol./ pos	Codierung/ Coding	Art. Nr. Rolle/ Part-No. Tape & Reel	Art. Nr. Schüttgut/ Part-No. Bulk material
SAL-12-FK4-X13/14/SMT	4	A	43-02103TR	43-02103
SAL-12-FK5-X13/14/SMT	5	A	43-02104TR	43-02104
SAL-12-FK8-X13/14/SMT	8	A	43-02105TR	43-02105

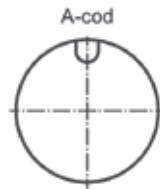

Flanschkupplung mit Schirmfeder|Frontmontage|Einbauhöhe 13,0 mm
 Female Socket with shielding | Frontmounting | Installation Height 13,0 mm

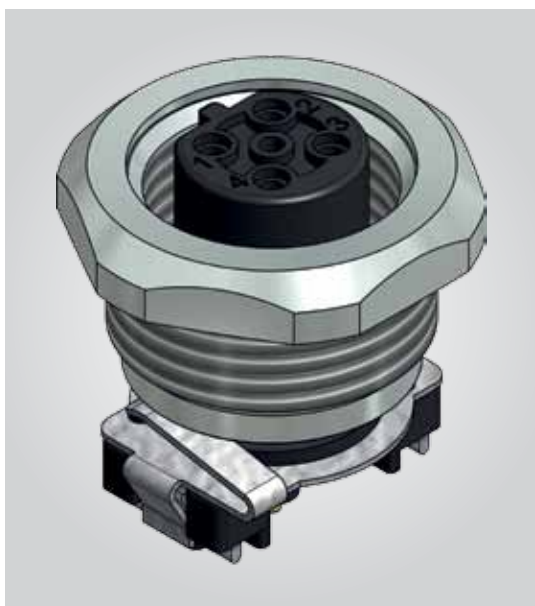

Bezeichnung/ Description	pol./ pos	Codierung/ Coding	Art. Nr. Rolle/ Part-No. Tape & Reel	Art. Nr. Schüttgut/ Part-No. Bulk material
SAL-12S-FK4-X13/14/SMT	4	A	43-02106TR	43-02106
SAL-12S-FK5-X13/14/SMT	5	A	43-02107TR	43-02107
SAL-12S-FK8-X13/14/SMT	8	A	43-02108TR	43-02108
SAL-12B-FK4-X13/14/SMT	4	B	43-02123TR	43-02123
SAL-12B-FK5-X13/14/SMT	5	B	43-02124TR	43-02124
SAL-12D-FK4-X13/14/SMT	4	D	43-02128TR	43-02128

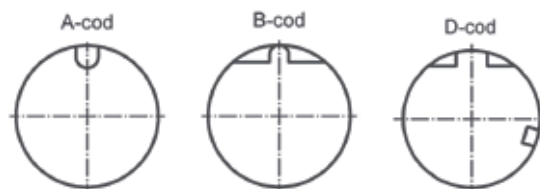

Flanschstecker|Frontmontage|Einbauhöhe 9,0 mm
Male Socket | Frontmounting | Installation Height 9,0 mm

Bezeichnung/ Description	pol./ pos	Codierung/ Coding	Art. Nr. Rolle/ Part-No. Tape & Reel	Art. Nr. Schüttgut/ Part-No. Bulk material
SAL-12-FS4-X9/14/SMT	4	A	43-02109TR	43-02109
SAL-12-FS5-X9/14/SMT	5	A	43-02110TR	43-02110
SAL-12-FS8-X9/14/SMT	8	43-02111TR	43-02111	

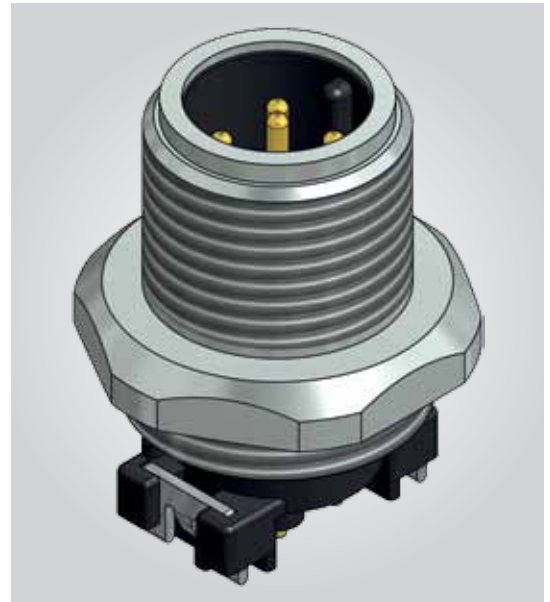

Flanschstecker mit Schirmfeder|Frontmontage|Einbauhöhe 9,0 mm
Male Socket with shielding | Frontmounting | Installation Height 9,0 mm

Bezeichnung/ Description	pol./ pos	Codierung/ Coding	Art. Nr. Rolle/ Part-No. Tape & Reel	Art. Nr. Schüttgut/ Part-No. Bulk material
SAL-12S-FS4-X9/14/SMT	4	A	43-02112TR	43-02112
SAL-12S-FS5-X9/14/SMT	5	A	43-02113TR	43-02113
SAL-12S-FS8-X9/14/SMT	8	A	43-02114TR	43-02114
SAL-12B-FS4-X9/14/SMT	4	B	43-02125TR	43-02125
SAL-12B-FS5-X9/14/SMT	5	B	43-02126TR	43-02126

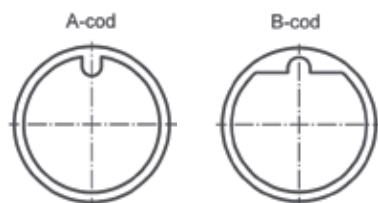
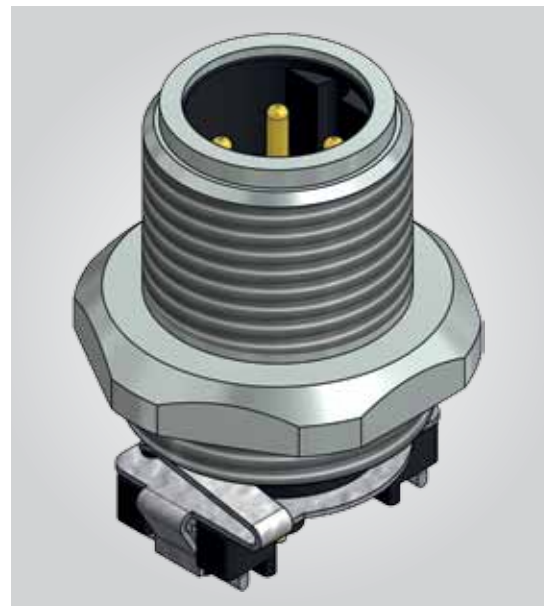

Flanschstecker|Frontmontage|Einbauhöhe 9,0 mm
 Male Socket | Frontmounting | Installation Height 9,0 mm

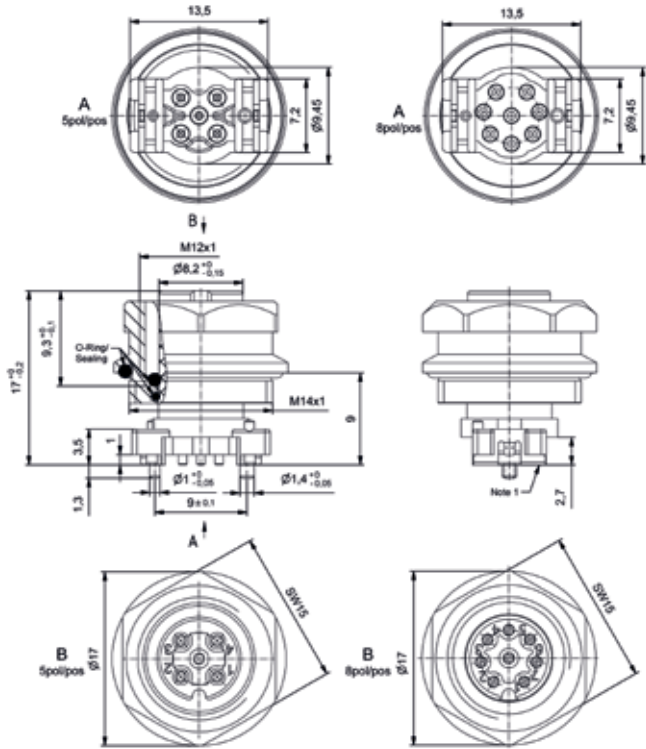

Layout Vorschlag 4-, 5-pol/
 Layout proposal 4-, 5-pos

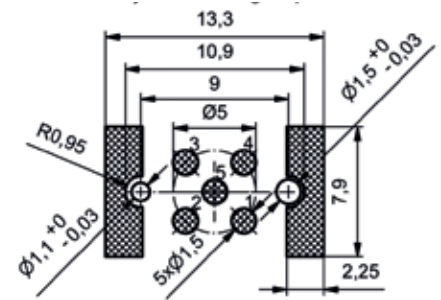

Flanschstecker mit Schirmfeder|
 Frontmontage|Einbauhöhe 9,0 mm
 Male Socket with shielding |
 Frontmounting | Installation Height 9,0 mm

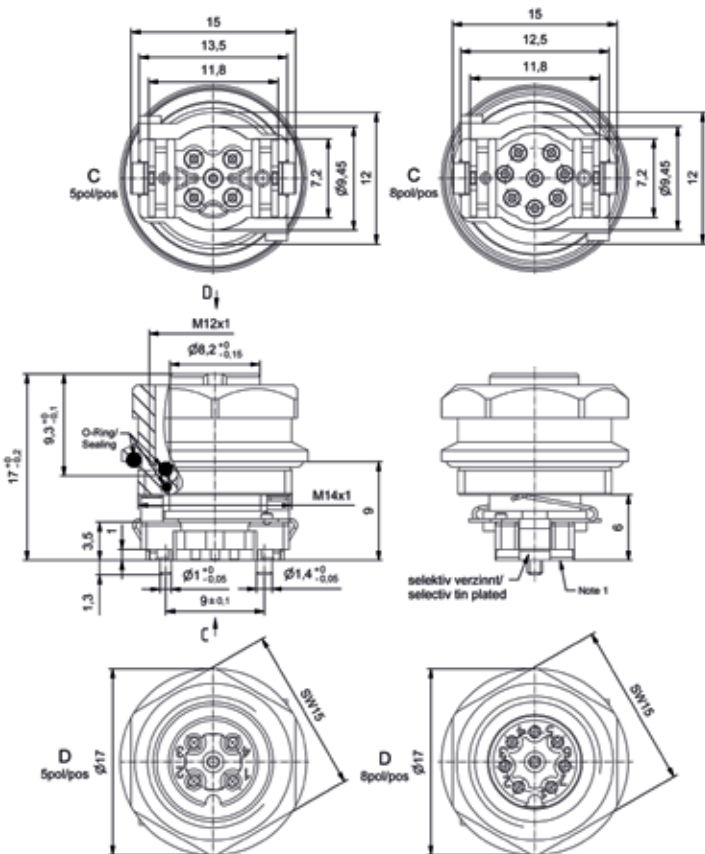

Layout Vorschlag 8-pol/
 Layout proposal 8-pos

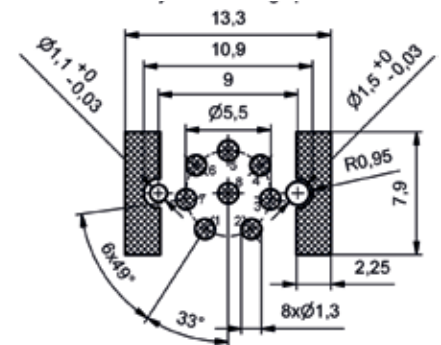

Note:
 Koplanarität aller Kontakte, Lötbleche
 und Schirmblech max 0,1 mm/
 Coplanarity of all contacts, soldering sheets
 and shroud max 0,1 mm

Flanschkupplung|Frontmontage|Einbauhöhe 13,0 mm
 Female Socket | Frontmounting | Installation Height 13,0 mm

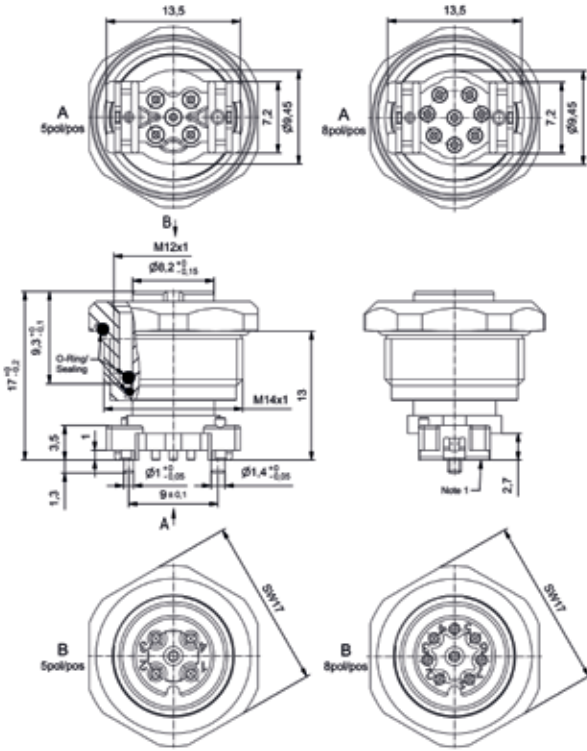

Layout Vorschlag 4-, 5-pol
 Layout proposal 4-, 5-pos

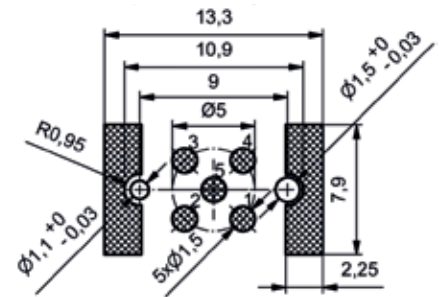

Flanschkupplung mit Schirmfeder|
 Frontmontage|Einbauhöhe 13,0 mm
 Female Socket with shielding |
 Frontmounting | Installation Height 13,0 mm

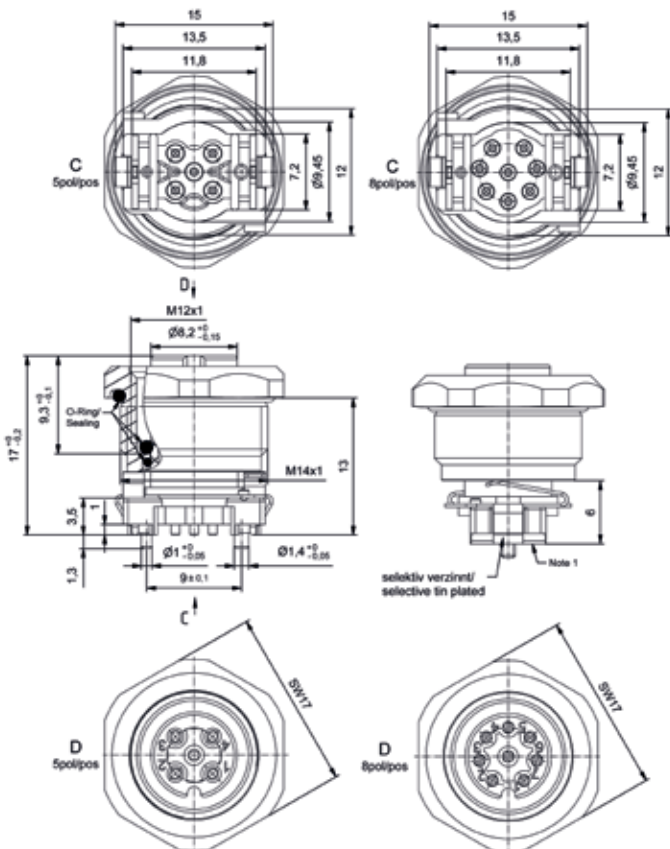

Layout Vorschlag 8-pol/
 Layout proposal 8-pos

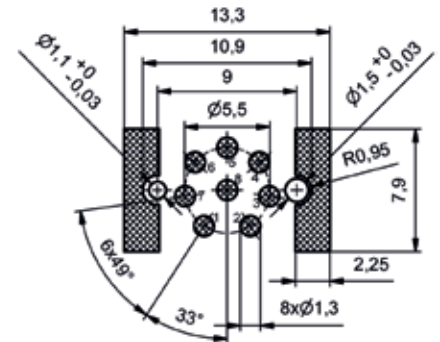

Note:
 Koplanarität aller Kontakte, Lötblech
 und Schirmblech max 0,1 mm/
 Coplanarity of all contacts, soldering sheets
 and shroud max 0,1 mm

Flanschstecker|Frontmontage|Einbauhöhe 9,0 mm
 Male Socket | Frontmounting | Installation Height 9,0 mm

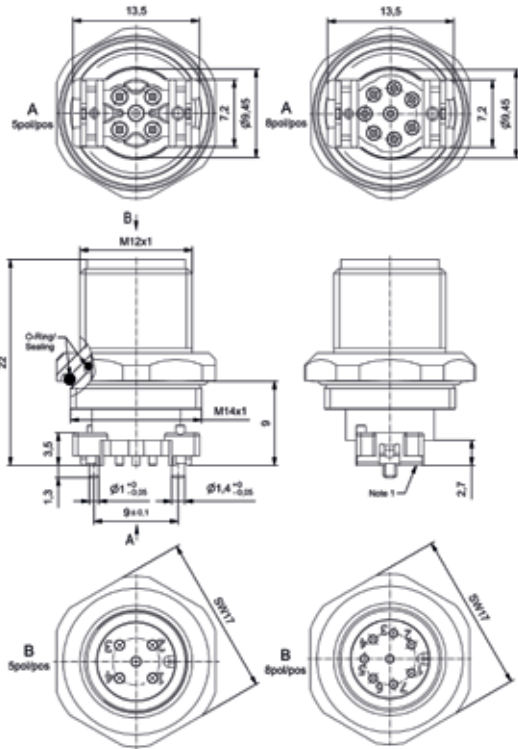

Layout Vorschlag 4-, 5-pol/
 Layout proposal 4-, 5-pos

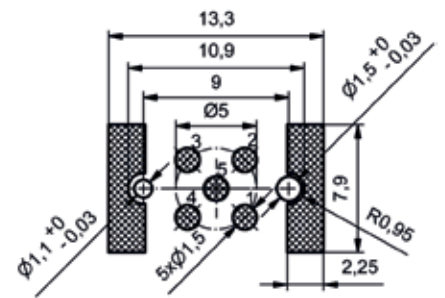

Flanschstecker mit Schirmfeder|
 Frontmontage|Einbauhöhe 9,0 mm
 Male Socket with shielding |
 Frontmounting | Installation Height 9,0 mm

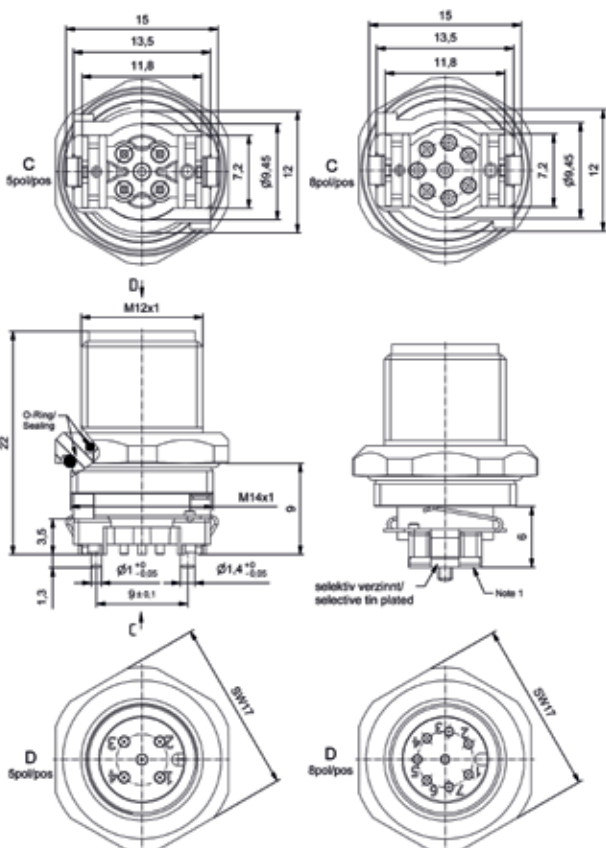

Layout Vorschlag 8-pol/
 Layout proposal 8-pos

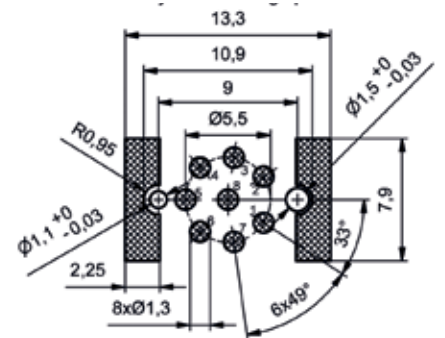

Note:
 Koplanarität aller Kontakte, Lötbleche
 und Schirmblech max 0,1 mm/
 Coplanarity of all contacts, soldering sheets
 and shroud max 0,1 mm

Kupplung mit Schirmfeder|Einbauhöhe 9,0 mm|

Gehäusewandstärke 3,0 mm

Female Socket with shielding | Installation Height 9,0 mm |

Casing wall thickness 3,0 mm

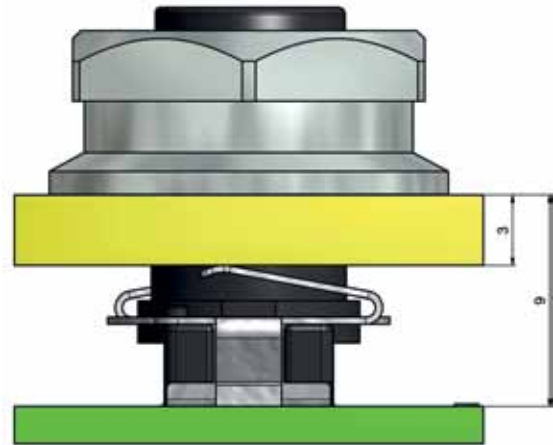
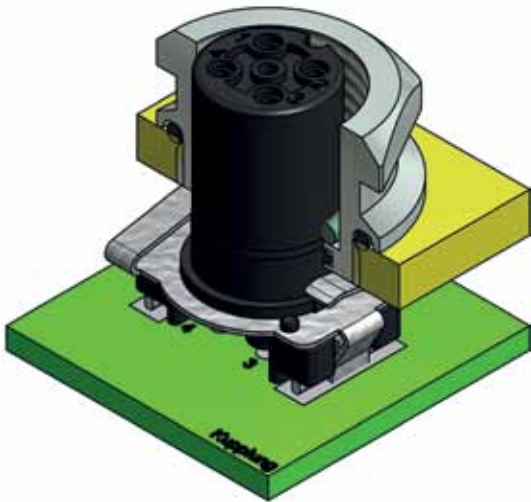

Radiale und axiale Abdichtung erfolgt durch Einsatz von O-Ringen. Abdichtung wird auch ohne Gegenstecker erreicht.

Radial and axial sealing is achieved by the use of o-rings. The sealing is achieved without mating connector.

Kupplung|Einbauhöhe 9,0 mm|

Gehäusewandstärke 1,0 mm + Sechskantmutter

Female Socket | Installation Height 9,0 mm |

Casing wall thickness 1,0 mm + Hexagon nut

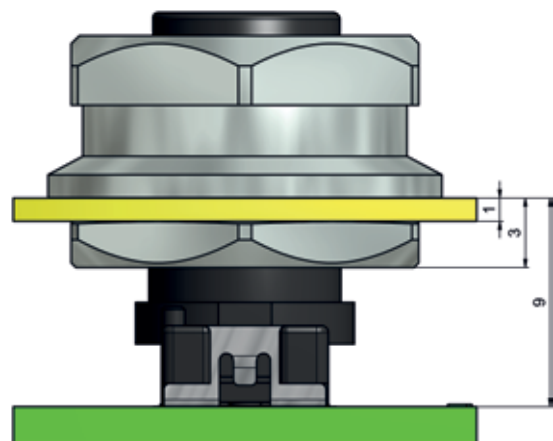
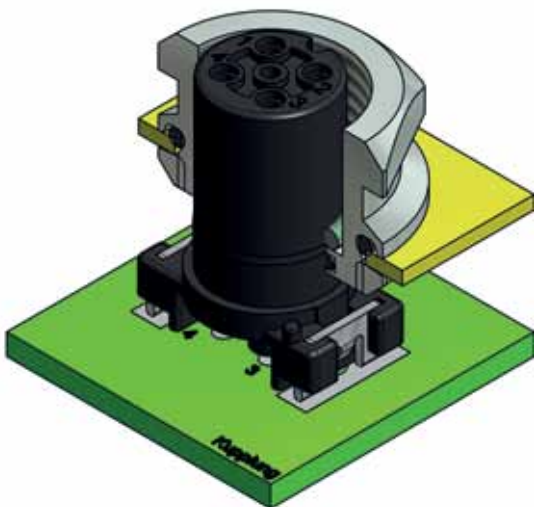

Bei Gehäusewandstärke kleiner als 2 mm bzw. bei Durchgangsbohrungen, sollte eine Sechskantmutter (Art.-Nr. 43-02132) auf der Gehäuseinnenseite eingesetzt werden.

It is necessary to use a nut (Art.-No. 43-02132) for fastening the housing, if the panel wall thickness is thinner than 2 mm or a through hole panel cut out is used.

Kupplung mit Schirmfeder|Einbauhöhe 13,0 mm|

Gehäusewandstärke 3,0 mm

Female Socket shielded | Installation Height 13,0 mm |

Casing wall thickness 3,0 mm

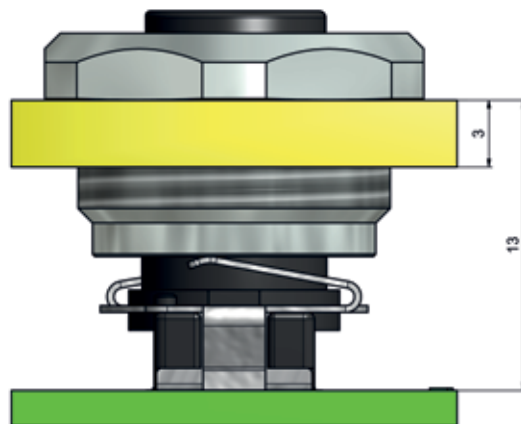
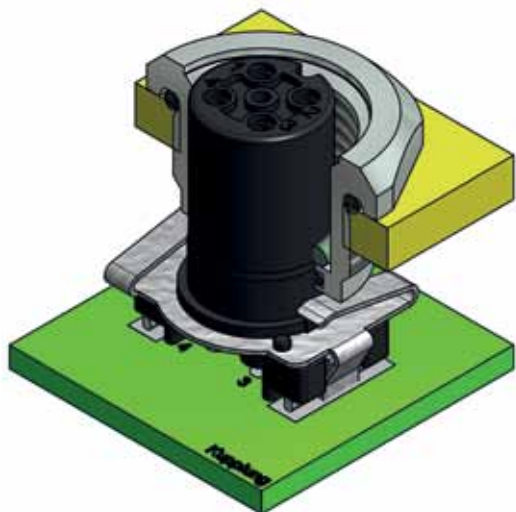

Bei Gehäusewandstärke kleiner als 2 mm bzw. bei Durchgangsbohrungen, sollte eine Sechskantmutter (Art.-Nr. 43-02132) auf der Gehäuseinnenseite eingesetzt werden.

It is necessary to use a nut (Art.-No. 43-02132) for fastening the housing, if the panel wall thickness is thinner than 2 mm or a through hole panel cut out is used.

Stecker mit Schirmfeder|Einbauhöhe 9,0 mm|

Gehäusewandstärke 1,0 mm + Sechskantmutter

Male Socket shielded | Installation Height 9,0 mm |

Casing wall thickness 1,0 mm + Hexagon nut

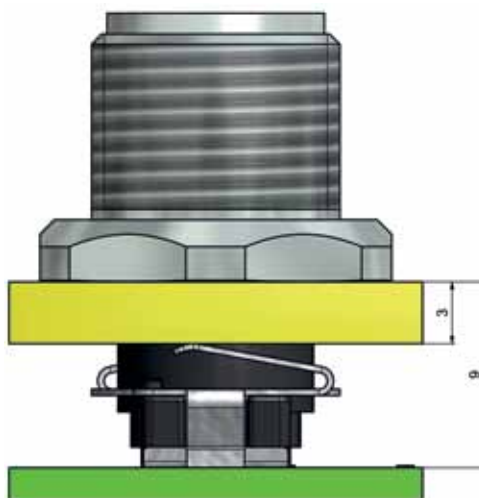
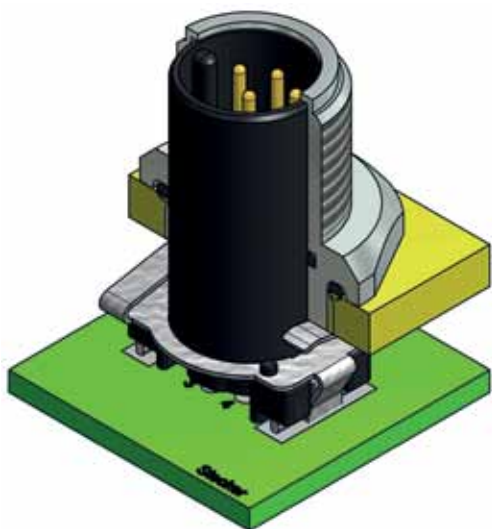

Abdichtung erfolgt durch Einsatz von O-Ringen und ist auch ohne Gegenstecker gewährleistet. Die Anschlußkräfte des Gegensteckers werden durch das Flanschgehäuse abgefangen.

Sealing is achieved with o-rings and tightness is also guaranteed in unmated condition. The mating force applied by the mating connector is secured by the housing.

1. gurtverpackung/Tape and reel packaging Verpackungseinheit/Packaging unit 75 Stk./Rolle/75 pcs./Reel

Beispiel: Gurtverpackung

Sample: Tape and reel packaging

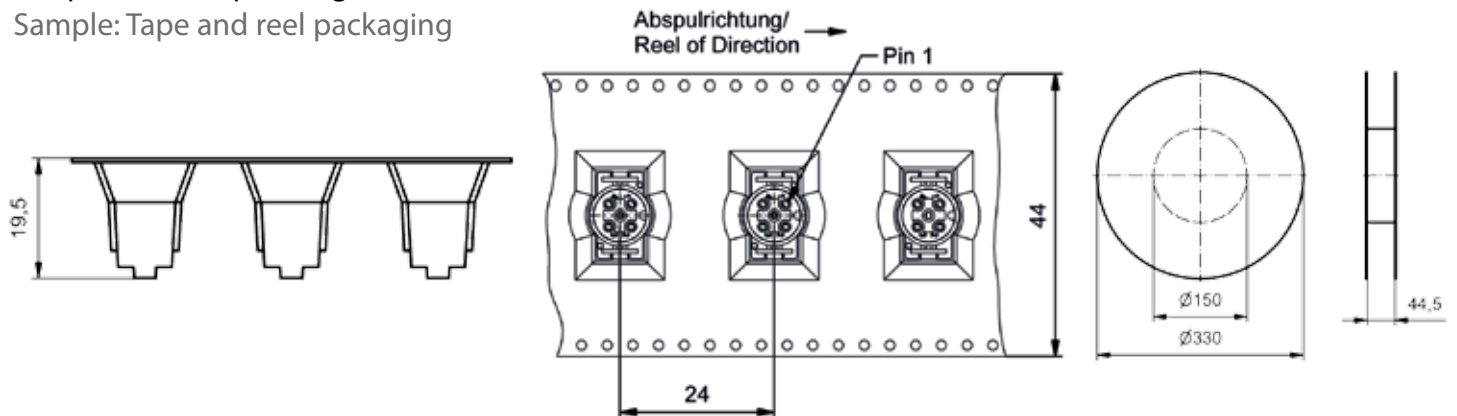

2. Schüttgut/Bulk material

- a) ungeschirmte Ausführung/Unshielded version: Polybeutel/Polybag
- b) geschirmte Ausführung/Shielded version: Faltschachtel/Folded box

3. Trayverpackung auf Anfrage/ Tray Packaging on request

Beispiel/Sample

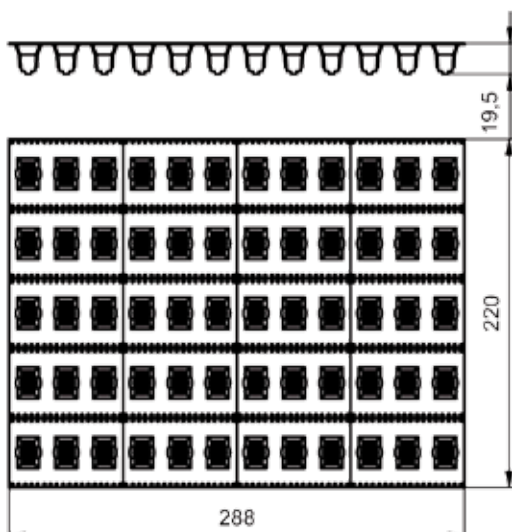

CONEC

Elektronische Bauelemente GmbH
Ostenfeldmark 16
59557 Lippstadt
Germany

Tel. +49 2941 765-0
Fax +49 2941 76565
E-Mail info@conec.de
www.conec.com

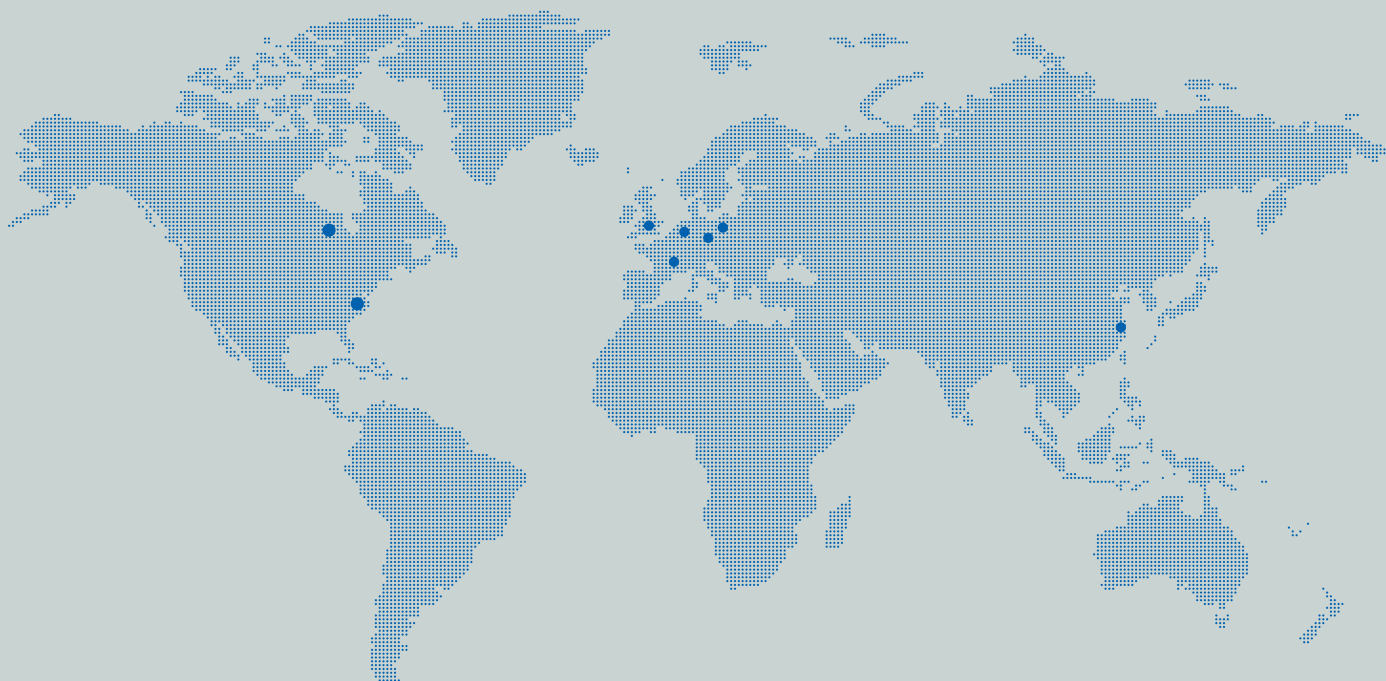

CONEC Corporation

125 Sun Pac Blvd.
Brampton Ontario
Canada L6S 5Z6
Tel. +1 905 790 2200
Fax +1 905 790 2201
E-Mail info@conec.com

CONEC

343 Technology Drive
Garner, NC, USA 27529
Tel. +1 919 460 8800
Fax +1 919 460 0141
E-Mail info@conec.com

CONEC (UK) Limited

Ringway House East
Kelvin Road
Newbury, Berkshire
RG14 2DB
Tel. +44 1635 36929
Fax +44 1635 36925
E-Mail info@conec.co.uk

CONEC Polska Sp. zo.o

ul.Szmaragdowa 10
52-215 Wrocław
Tel. +48 713744045
Fax +48 713744049
E-Mail info@conec.pl

CONEC s.r.o.

Loucka 119
76325 Ujezd
Czech Republic
Tel. +42 0577 350132
Fax +42 0577 350134
E-Mail info@conec.cz

CONEC France SARL

202 Rue des Chevreuils
30320 Poulx
Tel. +33 9 75267217
Fax +33 4 66570916
E-Mail info@conec.fr

CONEC (Shanghai)

Int. Trading Co., Ltd.
Rm. 715 Yongding Bldg.
No. 3388 Gong He Xin Rd.
200436 Shanghai
Tel. +86 21 66300930
Fax +86 21 66300911
E-Mail info@conec.cn

CONEC GmbH Schatz Electronic

Schubertstr. 14a
99096 Erfurt
Tel. +49 361 340110
Fax +49 361 340111
E-Mail info@schatz-electronic.de