

**NOTES:**

1. FOR WAVESOLDERING (SOLDER BATH TEMPERATURE 240°C FOR 5 SEC. AND SOLDER PREHEAT 120°C FOR 120 SEC.)
2. METALSHELLS: COPPER ALLOY; min. 315µin TIN over 40-80µin NICKEL
3. INSULATORS: PBT GF UL 94 V-0; BLACK
4. CONTACTS: COPPER ALLOY  
PLATING: 50µin HARD GOLD over min. 50µin NICKEL
5. THREADED SPACER CLIPS: COPPER ALLOY;  
min. 200µin TIN over 80µin NICKEL  
PCB-HOLE:  $\varnothing 3,1 \pm 0,1$ ; PCB THICKNESS 1,6mm
6. COLLARS: COPPER ALLOY; min. 200µin TIN over 80µin NICKEL
7. FRAME: ZINC DIE CAST; NICKEL PLATED
8. O-RING: SILICON; BLUE
9. SEALING COMPOUND: PUR; BLUE
10. HEXLOCKING SCREWS: STAINLESS STEEL
11. P.C.B. HOLE DRILLINGS + RECOMMENDED PANEL CUT-OUT ON SHEET 2
12. RECOMMENDED TORQUE FOR MOUNTING SCREW 35Ncm (3.1 in.LB) / max. 40Ncm (3.5 in.LB)
13. CONNECTOR IS PART MARKED: 6STD25SJR99E20X CONEC ABC

AT ALL TIMES WATER RESISTANT CONNECTORS NOT IN USE SHOULD BE COVERED WITH A CONEC WATER RESISTANT CAP OR WATER TIGHT HOOD.

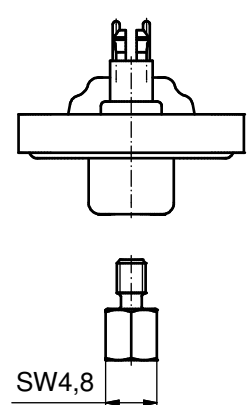
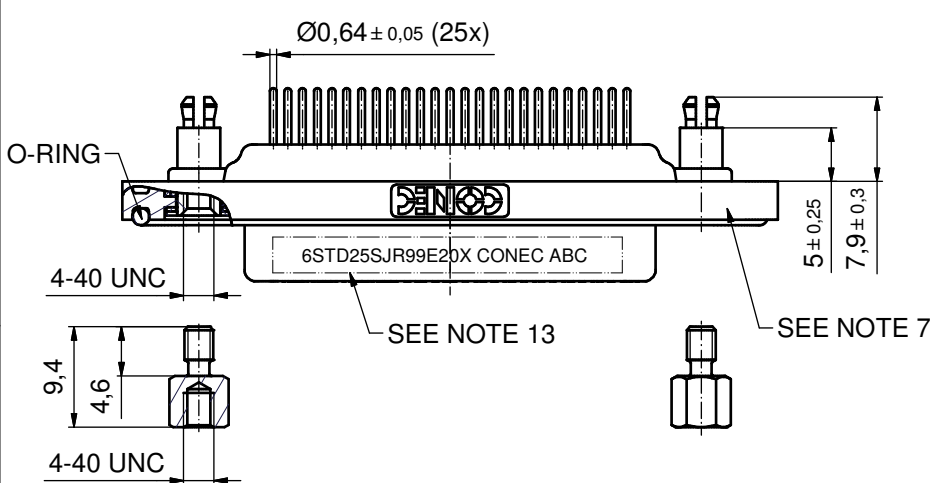
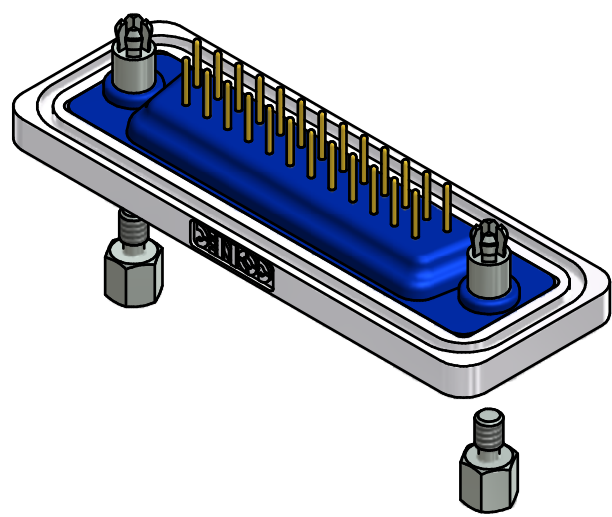
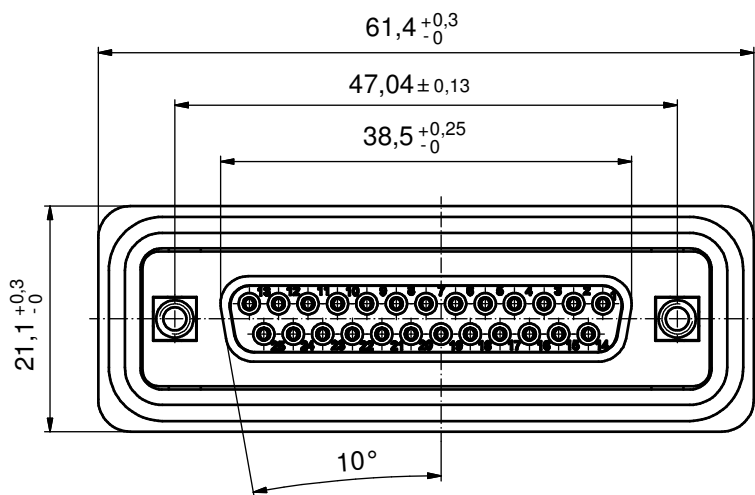
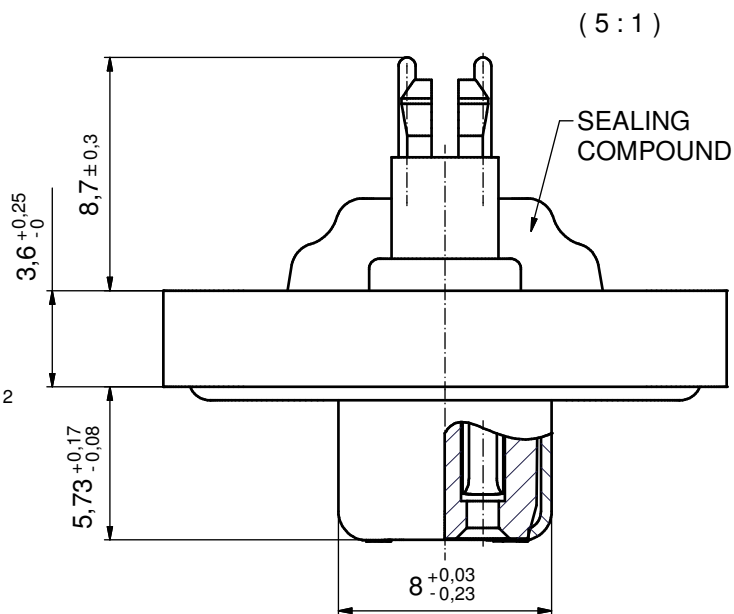

Directive 2002/95/EC RoHS compliant

THIS DRAWING MAY NOT BE COPIED OR REPRODUCED IN ANY WAY, AND MAY NOT BE PASSED ON TO A THIRD PARTY WITHOUT WRITTEN PERMISSION. OWNERSHIP AND COPYRIGHT OF CONEC GmbH DO NOT ALTER CAD DRAWING BY HAND	tolerance			scale: 2:1 (5:1)	
	dim. in mm			material: SEE NOTES	
	date	name	title:		
	drawn 26.10.2011	Henneboel	D-SUB FEMALE		
	appd. 26.10.2011	Fischer	25pos. SOLDER PIN STRAIGHT with threaded spacer clip and hexlocking screw		
norm		dwg no:		DIN-A3	
d-old		18K4A244		sh: 5/8	
a Original		part no: 6STD25SJR99E20X			
rev. description	date	name	<b>CONEC</b>		

# P.C.B. HOLE DRILLINGS ( P.C.B. TOP SIDE )

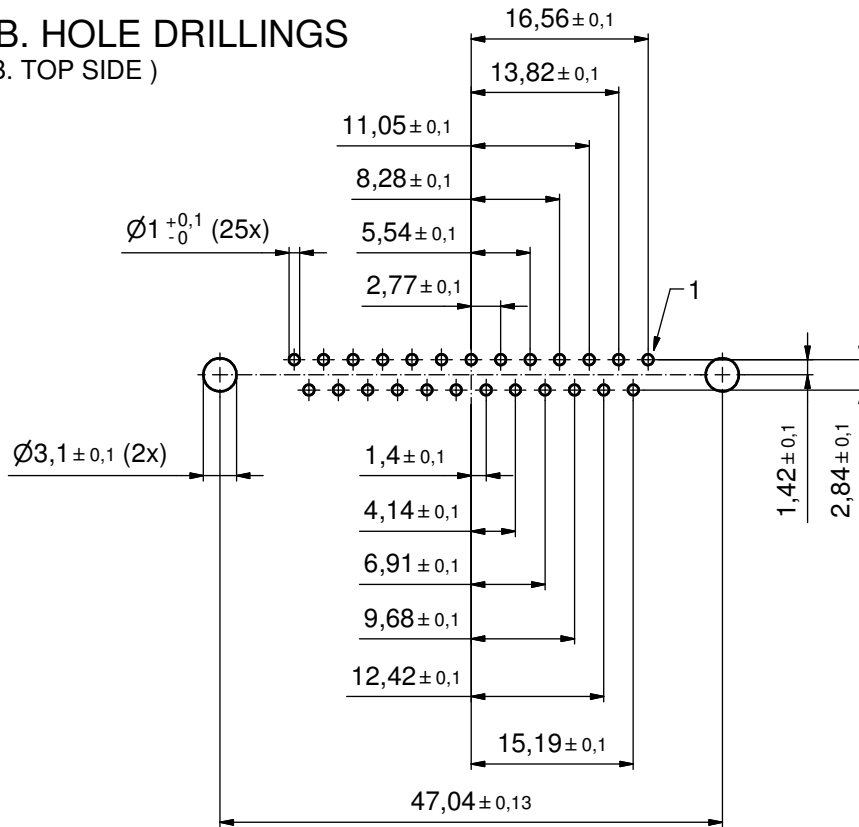

# RECOMMENDED PANEL CUT-OUT

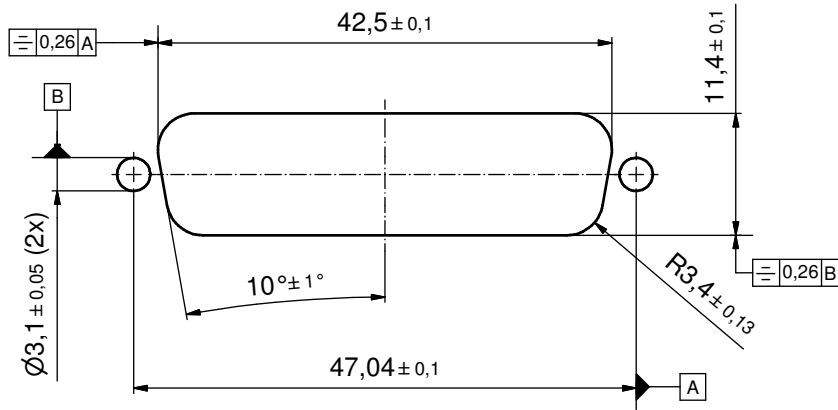

THIS DRAWING MAY NOT BE COPIED OR REPRODUCED IN ANY WAY, AND MAY NOT BE PASSED ON TO A THIRD PARTY WITHOUT WRITTEN PERMISSION. OWNERSHIP AND COPYRIGHT OF CONEC GmbH DO NOT ALTER CAD DRAWING BY HAND				tolerance		scale: 2:1	
				date	name	material: SEE SHEETS	
				drawn	26.10.2011	Henneboel	
				appd.	26.10.2011	Fischer	
				norm			
			d-old				
			a	Original		title: P.C.B. HOLE DRILLINGS RECOMMENDED PANEL CUT-OUT D-SUB FEMALE 25pos. SOLDER PIN STRAIGHT	
rev.	description	date	name	<b>CONEC</b> <sup>®</sup>		dwg no: 18K4A244	DIN-A3
						sh: 6/8	
						part no: SEE SHEETS	