

Assembly instructions field attachable socket M12x1 backmounting

Mounting

1. Strip insulation from wire, crimp the contact onto the wire
2. Assemble the contact carrier, start with the centre contact
3. Snap the assembled contact carrier into the connector housing
4. Snap connector housing into the socket housing, note the coding (Coding nose contact carrier / coding groove socket housing)
5. Mounting Seal on socket housing

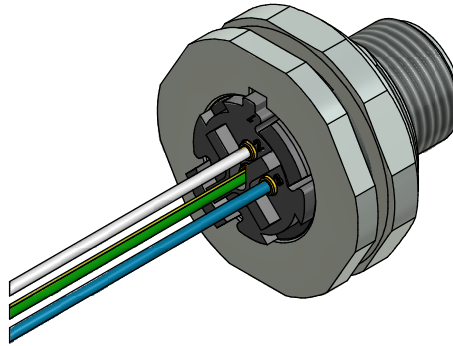

Disassembly

6. Press the locking hook on connector housing and pull the connector housing out of socket housing

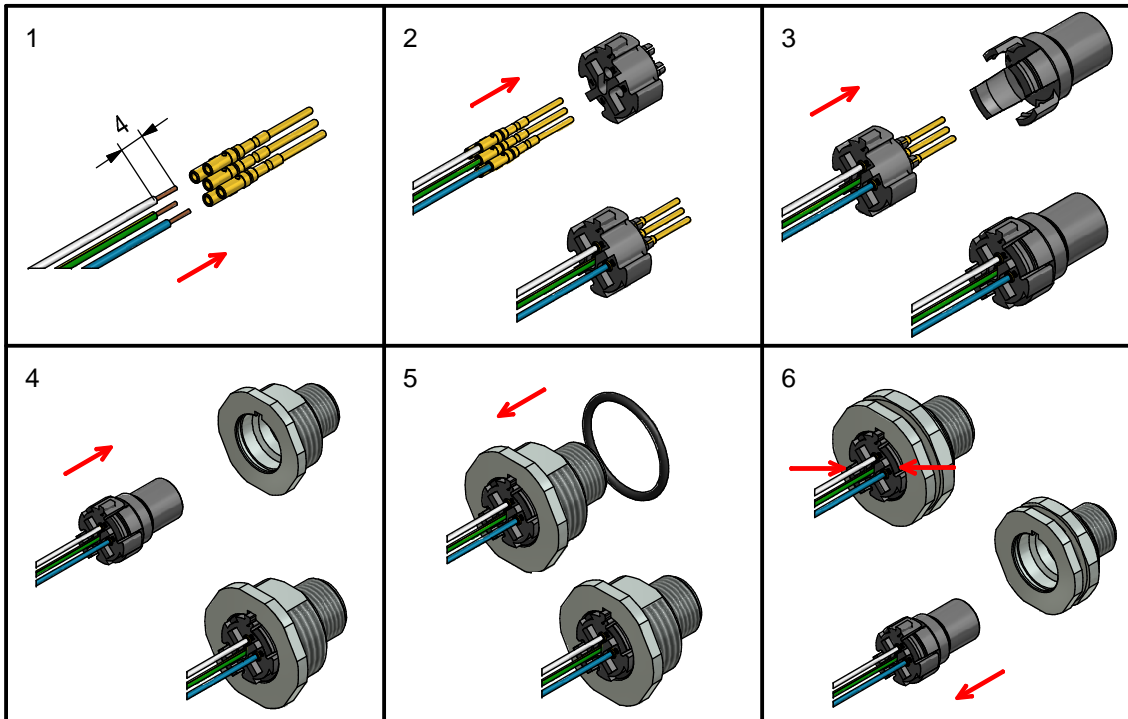

Structure

1. Wire (no part of delivery)
2. Contact
3. Contact carrier
4. Connector housing
5. Socket housing
6. Seal
7. Counternut

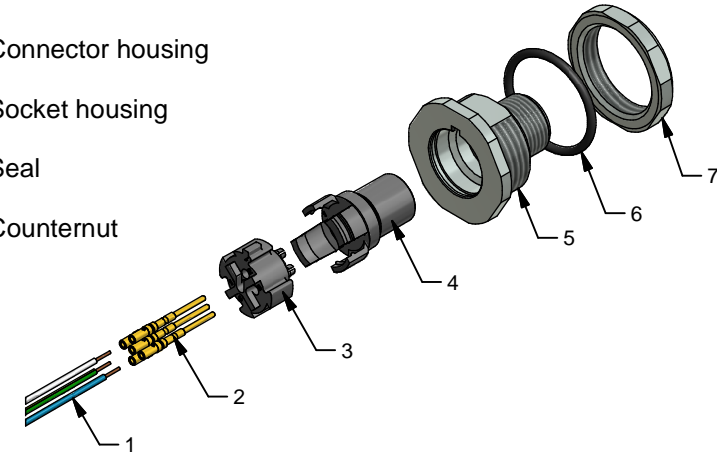

Article

- 43-02691 - SAL-12-FSHC4
- 43-02613 - SAL-12-FSHC5 / PIN 5 leading
- 43-02632 - SAL-12-FSHC5.1
- 43-02614 - SAL-12-FSHC8

Required accessories

Four-indent crimping tool
e.g. Rennsteig 8723 0000 61

Wire:
Cross section 0,34mm² - 0,5mm² for 4pos / 5pos
Cross section 0,25mm² - 0,34mm² for 8pos