

Tape & Reel - parts with adhesive pad Ø9 mm/
Tape & Reel - Artikel mit Klebepad Ø9 mm

**Technical specification/
Technische Daten:**

Rated Voltage/ Bemessungsspannung: IEC 61076-2-104	48 V AC / 60 V DC
Current rating/ Strombelastbarkeit: IEC 61076-2-104	3 A / 40 °C
Insulation resistance/ Isolationswiderstand: IEC 60512	>= 100 MΩ
Pollution degree/ Verschmutzungsgrad: IEC 60664-1	3/2
Degree of protection/ Schutzart: IEC 60529	IP67, mated condition/ im gesteckten Zustand
Temperature range/ Umgebungstemperatur:	-25 °C ... +95 °C
Mating cycles/ Steckzyklen: IEC 60512-9a	>= 100

**Materials/
 Werkstoffe:**

Contact/ Kontakt:	CuZn, Ni b / Au 0,2 gal.
Contact carrier/ Kontaktträger:	LCP GF, UL 94 V-0
Shroud/ Schirmblech:	CuSn, Ni / Sn
Suitable for reflow soldering max. 60 s / 250 °C/ Geeignet für Reflow Lötprozess max. 60 s / 250 °C	
Coplanarity of all contacts and shroud max. 0,1 mm/ Koplariät aller Kontakte und Schirmblech max. 0,1 mm	

**Layout proposal/
 Layout Vorschlag**

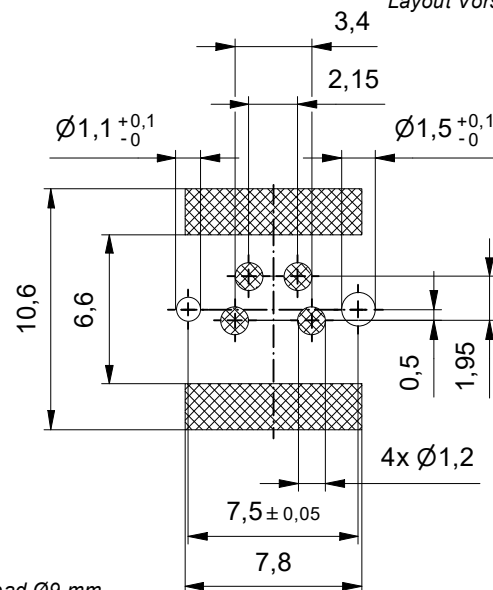

Part no packing unit tape & reel/ Art.-Nr. Verpackungseinheit Rolle:	Part no packing unit in bulk/ Art.-Nr. Verpackungseinheit lose:	Description/ Bezeichnung:	Pol/ Pol.:
42-01219TR	42-01219	SAL - 8S - IK4 / SMT	4



general tolerance/ Allgemeintoleranz:	0 ± 0,50 mm
	0,0 ± 0,25 mm
	0,00 ± 0,10 mm
	A ± 1,5°

	Date/Datum	Name
drawn/ gez.	19.02.2015	Gitinow
appd./ gepr.	16.03.2015	Schramm

Insulating body female M8x1 SMT, shielded
Isolierkörper Kupplung M8x1 SMT, geschirmt

Index: c ÄZ3-1132 27.01.2026 ABU

scale/ Maßstab:



dwg no /
 Z.-nr.:

42K1A745

DIN-
A4

see table/ siehe Tabelle

1 / 1

The reproduction, distribution and utilization of this document as well as the communication of its contents to others without express authorization is prohibited. Offenders will be held liable for the payment of damages. All rights reserved in the event of the grant of a patent, utility model or design. Weitergabe sowie Vervielfältigung dieses Dokuments, Verwertung und Mitteilung seines Inhalts sind verboten, soweit nicht ausdrücklich gestattet. Zuwiderhandlungen verpflichten zu Schadensersatz. Alle Rechte für den Fall der Patent-, Gebrauchsmuster- oder Geschmuckenscheinverletzung vorbehalten.