

Part no. / Part marked/ Art.-Nr. / Bedruckung:	Quality class/ Gütestufe:	Contact plating/ Kontakt Veredelung:	Capacitance value/ Kapazitätswert:
24-002153	3	Gold flash over nickel Gold über Nickel	370 pF ± 20 %
24-002152	2	20 µm hard gold over min. 50 µm nickel 20 µm Gold über min. 50 µm Nickel	
24-002151	1	30 µm hard gold over min. 50 µm nickel 30 µm Gold über min. 50 µm Nickel	
24-002163	3	Gold flash over nickel Gold über Nickel	830 pF ± 20 %
24-002162	2	20 µm hard gold over min. 50 µm nickel 20 µm Gold über min. 50 µm Nickel	
24-002161	1	30 µm hard gold over min. 50 µm nickel 30 µm Gold über min. 50 µm Nickel	
24-002173	3	Gold flash over nickel Gold über Nickel	1300 pF ± 20 %
24-002172	2	20 µm hard gold over min. 50 µm nickel 20 µm Gold über min. 50 µm Nickel	
24-002171	1	30 µm hard gold over min. 50 µm nickel 30 µm Gold über min. 50 µm Nickel	

**Technical specification/
Technische Daten:**

Working voltage/ Betriebsspannung:	100 VDC
Current rating/ Strombelastbarkeit:	7,5 A (UL), 5 A (CSA, VDE)
Insulation resistance/ Isolationswiderstand:	≥ 1 GΩ
Dielectric withstanding voltage/ Spannungsfestigkeit (DWV):	424 VDC
Temperature working range/ Umgebungstemperatur:	- 25 °C ... + 105 °C
Capacitance value/ Kapazitätswert:	see table/ siehe Tabelle
Mating cycles (see table)/ Steckzyklen (siehe Tabelle):	Quality class 3 = 50 Gütestufe 3 Quality class 2 = 200 Gütestufe 2 Quality class 1 = 500 Gütestufe 1

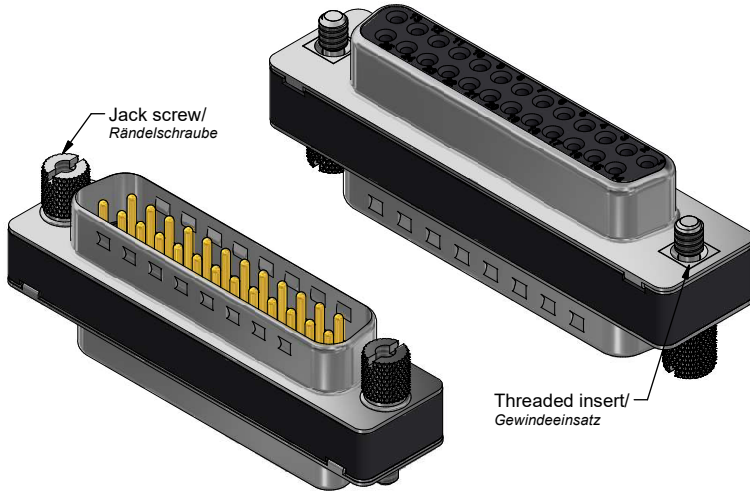

**Materials/
Werkstoffe:**

Contact/ Kontakt:	Cu alloy, Au over Ni
Insulator/ Isolierkörper:	High temp. PA UL94 V-0
Shell/ Gehäuse:	Steel, Sn over Ni
Threaded insert/ Gewindeeinsatz:	Cu alloy, Sn over Ni
Jack screw/ Rändelschraube:	Cu alloy, Ni

**Installation specification/
Montagedaten:**

Recommended torque value for thread/ Empfohlenes Drehmoment für Gewinde:	max. 6 in.LB/ max. 67 Ncm
---	------------------------------

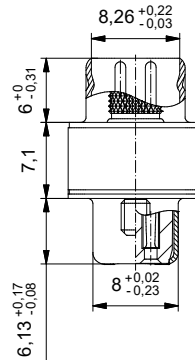
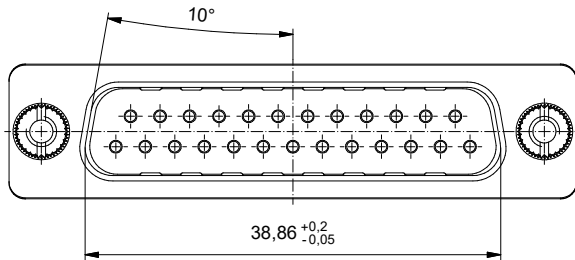
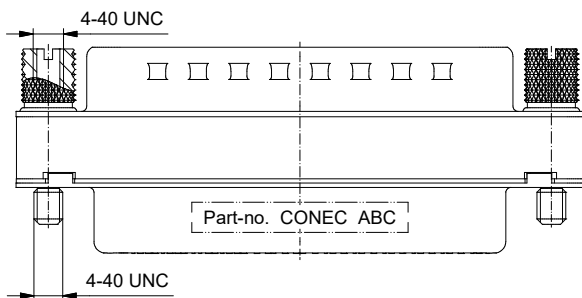
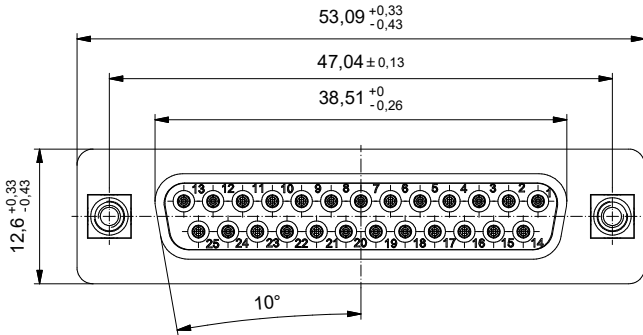

Index: a Original	Scale/Maßstab: 2:1		dim. in mm	D-SUB C-Filter Adapter 25pos. with jack screw 4-40 UNC D-SUB C-Filter Adapter 25pol. mit Rändelschraube 4-40 UNC	DIN-A3	
			Date/Datum			Name
			drawn/ges. 03.11.2021 appd./gepr. 04.11.2021			Unkrüer Lehmenkühler
RoHS compliant/konform			dwg no / Z.-nr.:	24K1A2098	1 / 1	

The reproduction, distribution and sale of this document as well as the communication of its contents to others without express authorization is prohibited. Otherwise will be held liable for the payment of damages. We hereby sever all responsibility from our company. Verantwortung für die Verbreitung, die Weitergabe und die Kommunikation dieses Dokuments übertragene Unternehmen, Vertriebspartner, Dienstleister, Zulieferer und Auftraggeber.