

used for: D-SUB

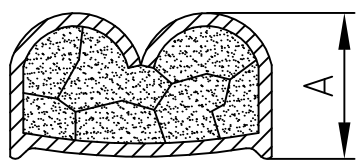

Wire size AWG	Crimp height A
24	0,68 - 0,86
22	0,68 - 0,86
20	0,68 - 0,86

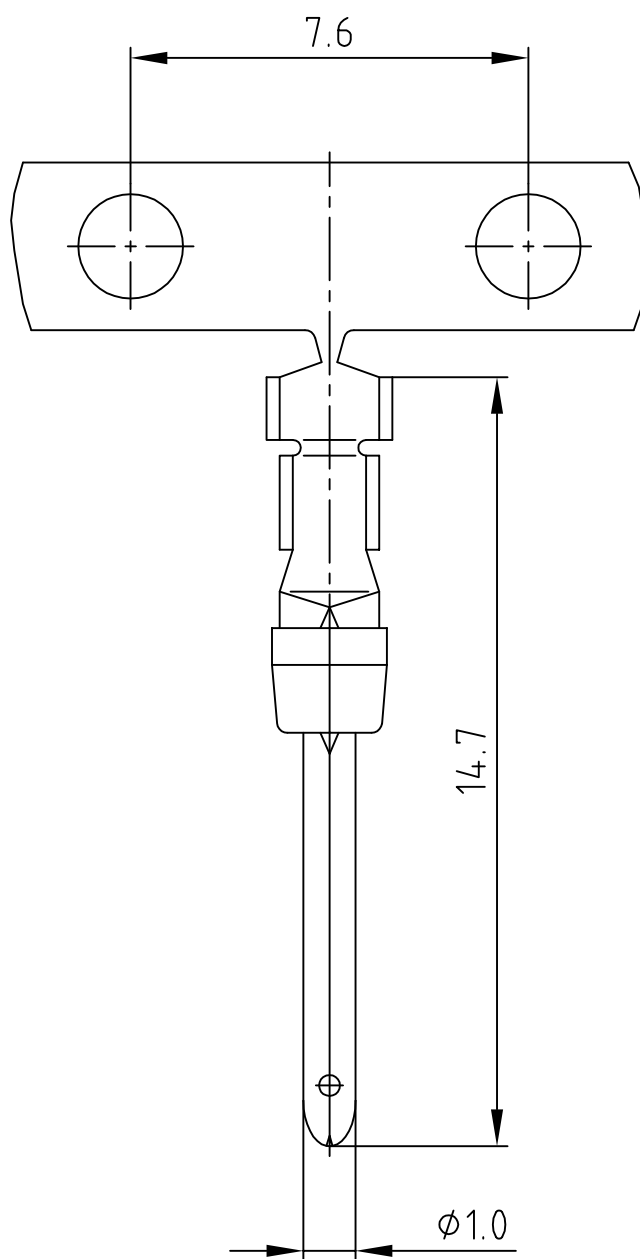

STRIPPING DIMENSIONS

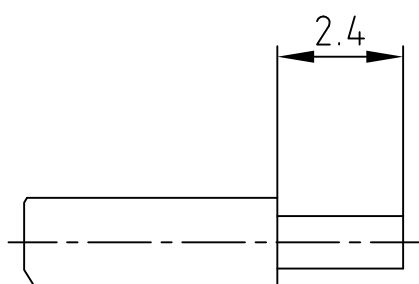

NOTES:

Material: Phosphor Bronze

(b) Finish: Gold Flash over Nickel in the Contact Area

Temperature Range: -55°C to +125°C

Rated Current: 7.5A

Contact Resistance: <= 10mOhm

Crimping: Use Crimp Tool 360X10079X

Directive 2002/95/EC RoHS compliant

THIS DRAWING MAY NOT BE COPIED OR REPRODUCED IN ANY WAY, AND MAY NOT BE PASSED ON TO A THIRD PARTY WITHOUT WRITTEN PERMISSION.  
 OWNERSHIP AND COPYRIGHT OF CONEC GmbH  
 DO NOT ALTER CAD DRAWING BY HAND

finish:				tolerance			 dim. in mm	scale: 5:1	
SEE NOTES								material: SEE NOTES	
				2008	date	name	title: PLUG CONTACT CRIMP AWG 24-20 (big spool wheeled left)		
				drawn	25.01.	Schmidt			
				appd.	25.01.	Mickenbecker			
				norm					
				d-old					
1 x b	Ä 4116	26.09.2011	Lehmen.				dwg no: AutoCAD 2006		DIN-A
a	Original						16K2A618		4
rev.	description	date	name				part no: 161A13369X		sh: 1/1

4

3

2

1