

1

pull gland [a], cable seal [b]*, and housing [c] on the cable

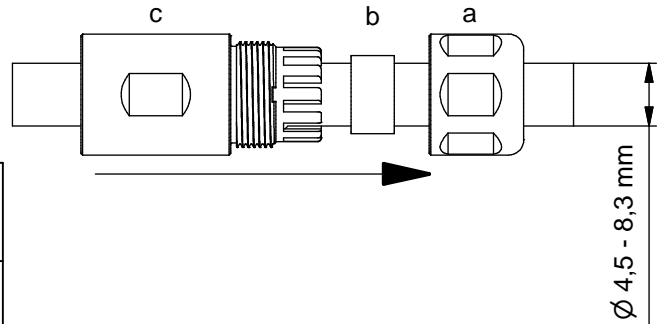

*

cable seal			
cable outer diameter [mm]	4,5 - 5,0	5,0 - 7,0	7,0 - 8,3

2

strip cable as shown in the drawing

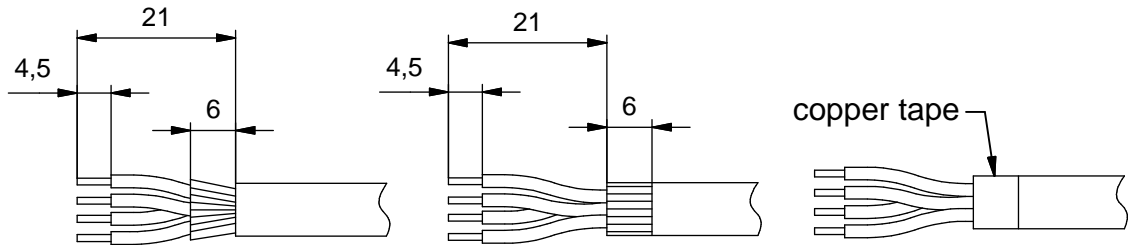

shorten braided shield, turn it over the cable jacket and wrap it with copper tape

3

crimp contacts with tool: 360X10329X
settings: see table

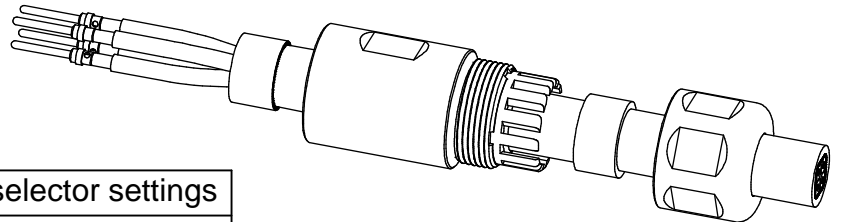

wire cross section	tool insert	selector settings
0,22 mm ² - 0,5 mm ² AWG 24 - AWG 20	360X20039X	7 for AWG 20 6 for AWG 22 5 for AWG 24
0,34 mm ² - 1,0 mm ² AWG 22 - AWG 18	360X20069X	6 for AWG 18 6 for AWG 20 5 for AWG 22

4

insert contacts in the contact carrier laterally

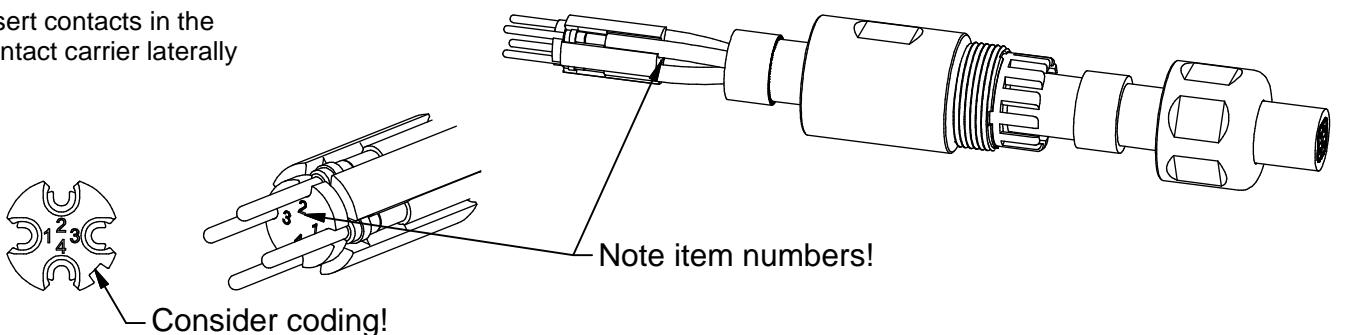

5

slide insert over the contact carrier

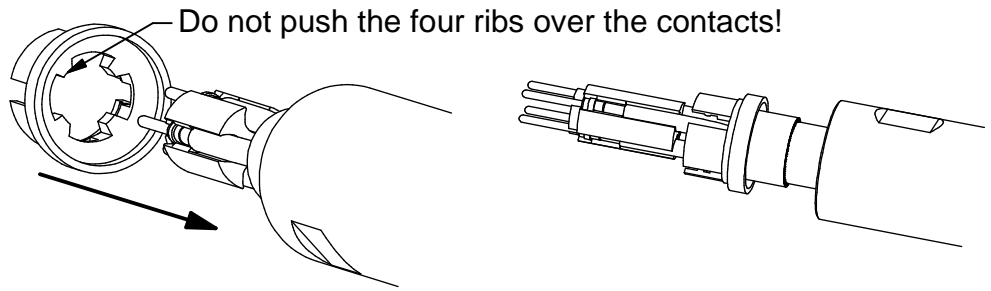

6

slide contact carrier into front housing

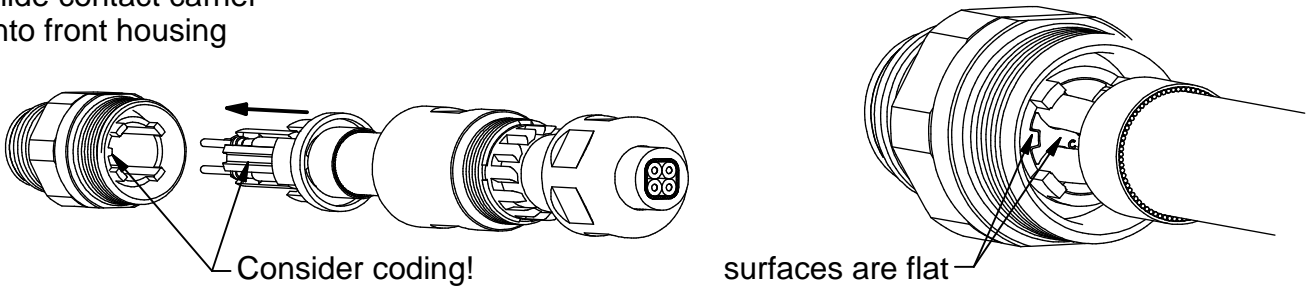

7

push in the insert

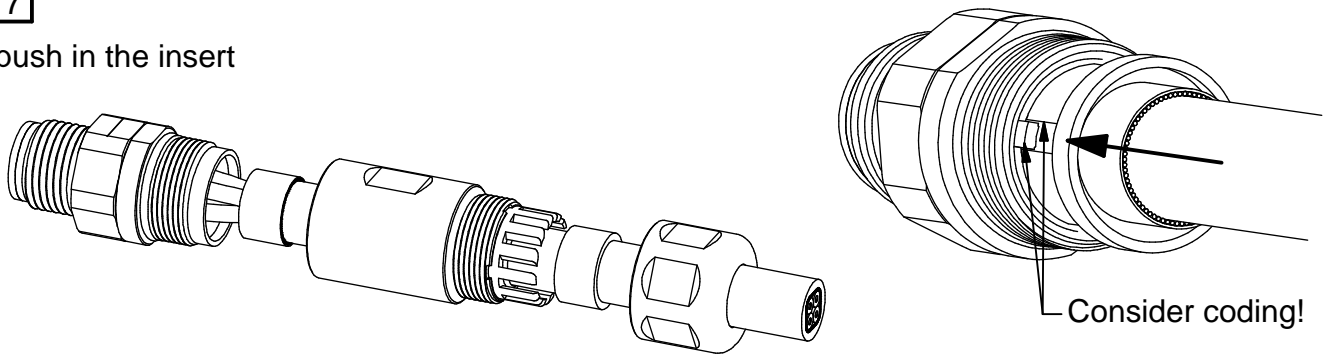

8

screw housing [c] until it stops
Conec tool:
36-000200
36-000320 for SW15

push cable seal [b]
into the cable cage

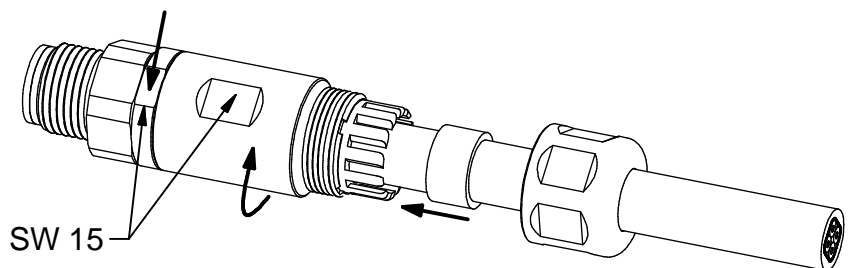

9

tighten gland to a
torque of min. 100 Ncm

