

NOTES:

1. METALSHELLS: STEEL; min. 315µin TIN over 40-80µin NICKEL
2. INSULATORS: PBT GF UL 94 V-0; GREEN
3. SIGNAL CONTACTS: COPPER ALLOY;
PLATING: GOLD FLASH over NICKEL
4. NO CONTACTS ON POS. A1 - A4
5. THREADED INSERTS: COPPER ALLOY; min. 200µin TIN over 80µin NICKEL
6. METAL BRACKETS: ZINC DIE CAST; 300µin COPPER/ 40-120µin NICKEL/ 120-200µin NICKEL
7. PCB-SNAPS: COPPER ALLOY; min. 200µin TIN over 80µin NICKEL
PCB-HOLE: ø3,1±0,1mm; PCB-THICKNESS: 1,6mm
8. P.C.B. HOLE DRILLINGS ON SHEET 2
9. MAXIMUM TORQUE VALUE FOR THREAD: 6 in.LB
10. CONNECTOR IS PART MARKED: 3009W4SAT99N40X CONEC ABC

RoHS compliant

| | | | | | |
|---|------------------|--------------------------|--|---------------------|--|
| THIS DRAWING MAY NOT BE COPIED OR REPRODUCED IN ANY WAY, AND MAY NOT BE PASSED ON TO A THIRD PARTY WITHOUT WRITTEN PERMISSION. OWNERSHIP AND COPYRIGHT OF CONEC GmbH DO NOT ALTER CAD DRAWING BY HAND | tolerance | | dim. in mm | scale: 2:1 (5:1) | |
| | | | | material: SEE NOTES | |
| | date | name | title: | | |
| | drawn 25.02.2016 | Unkrüer | D-SUB COM. FEMALE 90° 9W4S with threaded insert, metal bracket and snap | | |
| | appd. 25.02.2016 | Lehmenkühler | | | |
| norm | | dwg no: | | DIN-A3 | |
| d-old | | 13K1A5155 | | sh: 1/2 | |
| rev. a | Original | part no: 3009W4SAT99N40X | | | |
| description | date | | | | |

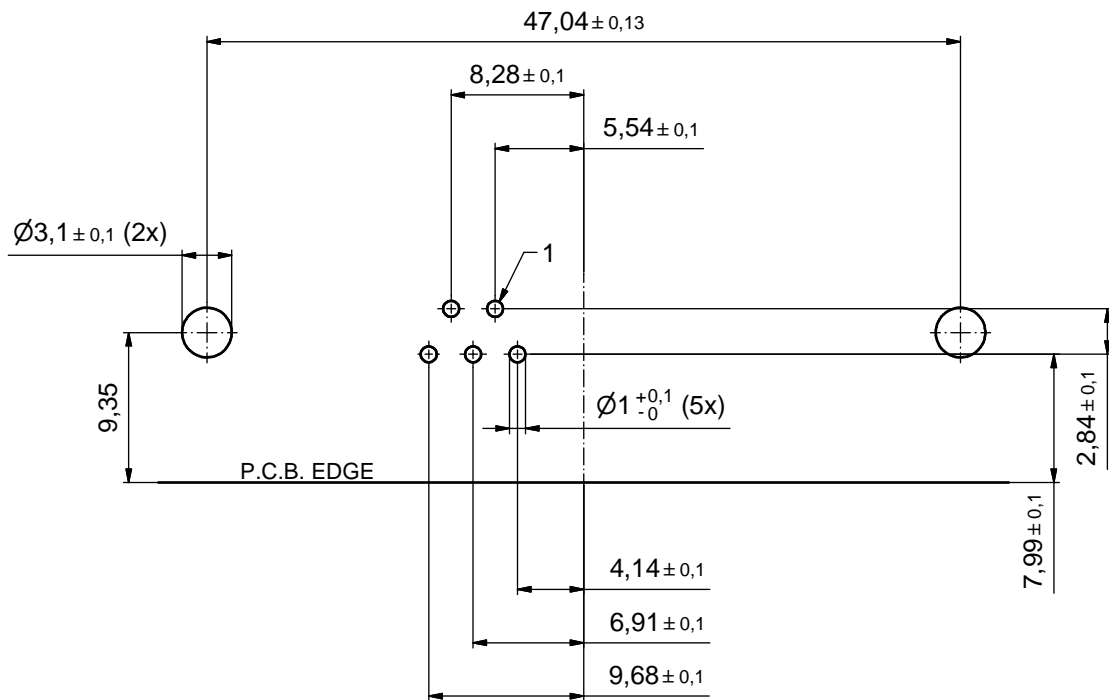

P.C.B. HOLE DRILLINGS
(P.C.B. TOP SIDE)

| | | | | | | |
|--|------------------|--------------|-----------|--|---------|-----------------------|
| THIS DRAWING MAY NOT BE COPIED OR REPRODUCED IN ANY WAY, AND MAY NOT BE PASSED ON TO A THIRD PARTY WITHOUT WRITTEN PERMISSION. OWNERSHIP AND COPYRIGHT OF CONEC GmbH DO NOT ALTER CAD DRAWING BY HAND | | | | tolerance | | scale: 3:1 |
| | | | | dim. in mm | | material: SEE SHEET 1 |
| | date | name | | title: | | |
| | drawn 25.02.2016 | Unkrüer | | P.C.B. HOLE DRILLINGS | | |
| | appd. 25.02.2016 | Lehmenkühler | | D-SUB COMBINATION FEMALE 90° 9W4S | | |
| | norm | | | with threaded insert, metal bracket and snap | | |
| | d-old | | | dwg no: | | DIN-A3 |
| rev. a | Original | | 13K1A5155 | | sh: 2/2 | |
| rev. | description | date | name | part no: SEE SHEET 1 | | |

