

Part no. / Part marked/ Art.-Nr. / Bedruckung:	Quality class/ Gütestufe:	Contact plating/ Kontakt Veredelung:	Capacitance value/ Kapazitätswert:
24-003223	3	Gold flash over nickel <i>Gold über Nickel</i>	370 pF ± 20 %
24-003222	2	20 µin hard gold over min. 50 µin nickel <i>20 µin Gold über min. 50 µin Nickel</i>	
24-003221	1	30 µin hard gold over min. 50 µin nickel <i>30 µin Gold über min. 50 µin Nickel</i>	
24-003233	3	Gold flash over nickel <i>Gold über Nickel</i>	830 pF ± 20 %
24-003232	2	20 µin hard gold over min. 50 µin nickel <i>20 µin Gold über min. 50 µin Nickel</i>	
24-003231	1	30 µin hard gold over min. 50 µin nickel <i>30 µin Gold über min. 50 µin Nickel</i>	
24-003243	3	Gold flash over nickel <i>Gold über Nickel</i>	1300 pF ± 20 %
24-003242	2	20 µin hard gold over min. 50 µin nickel <i>20 µin Gold über min. 50 µin Nickel</i>	
24-003241	1	30 µin hard gold over min. 50 µin nickel <i>30 µin Gold über min. 50 µin Nickel</i>	

**Technical specification/  
Technische Daten:**

Working voltage/ Betriebsspannung:	100 VDC
Current rating/ Strombelastbarkeit:	5 A
Insulation resistance/ Isolationswiderstand:	≥ 1 GΩ
Dielectric withstanding voltage/ Spannungsfestigkeit (DWV):	424 VDC
Temperature working range/ Umgebungstemperatur:	- 25 °C ... + 105 °C
Capacitance value/ Kapazitätswert:	see table/ siehe Tabelle
Mating cycles (see table)/ Steckzyklen (siehe Tabelle):	Quality class 1 = 500 Gütestufe 1 Quality class 2 = 200 Gütestufe 2 Quality class 3 = 50 Gütestufe 3

**Materials/  
Werkstoffe:**

Contact/ Kontakt:	Cu alloy, Au over Ni Contact tails pretinned/ Kontaktspitzen verzinkt
Insulator/ Isolierkörper:	High temp. PA UL 94 V-0
Shell/ Gehäuse:	Steel, Sn over Ni
Threaded insert/ Gewindeinsatz:	Cu alloy, Sn over Ni
Collar/ Scheibe:	Cu alloy, Sn over Ni

**Installation specification/  
Montagedaten:**

Solder parameter/ Lötparameter:	
Solder preheat temperature/ Vorheiztemperatur:	100 °C for 30 sec./ 100 °C für 30 Sek.
Solder bath temperature/ Lötbadtemperatur:	260 °C for 5 sec./ 260 °C für 5 Sek.
Recommended torque value for thread/ Empfohlenes Drehmoment für Gewinde:	max. 6 in.LB/ max. 67 Ncm

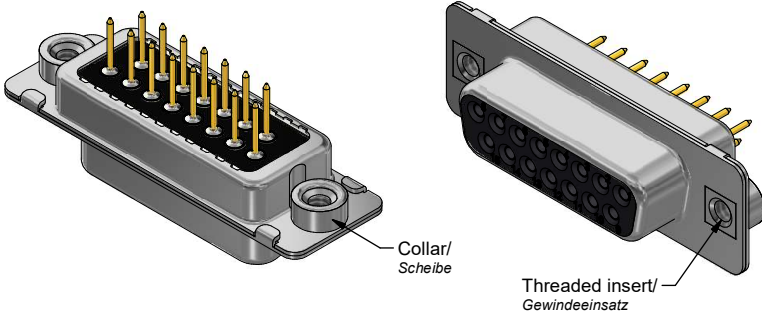

PCB hole drillings  
(PCB top side)  
Leiterplattenbohrbild  
(Leiterplatten Oberseite)

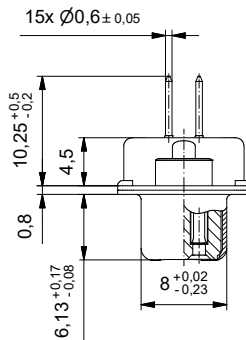
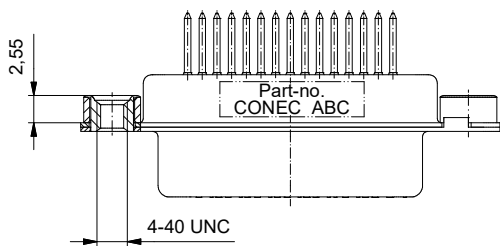
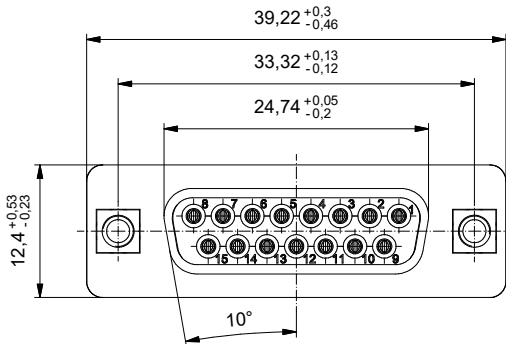
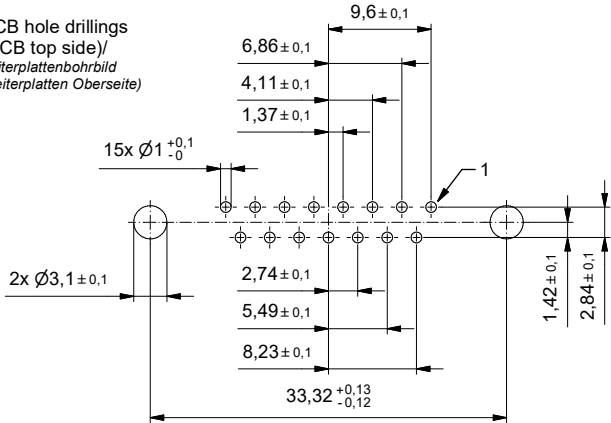

Index: a Original	Scale/Maßstab: 2:1		dwg no / Z.-nr.: 24K1A2161	DIN-A3
RoHS compliant/ konform				1 / 1

The reproduction, distribution and sale of this document as well as the communication of its contents to others without express authorization is prohibited. Offenders will be held liable for the payment of damages. We reserve the right to withdraw advertising space at any time without notice.